



MUNICIPALITY OF KINCARDINE

MUNICIPAL DEVELOPMENT AND SERVICING GUIDELINES

MUNICIPALITY OF KINCARDINE

MUNICIPAL DEVELOPMENT AND SERVICING GUIDELINES

September 10, 2024

Amended March 12, 2026

Section 7.5

B. M. ROSS AND ASSOCIATES LIMITED
Engineers and Planners
62 North Street
Goderich, ON N7A 2T4

Phone: 519-524-2641
www.bmross.net

File No. 16128

TABLE OF CONTENTS

1.0	GENERAL	1
1.1	Definitions	1
1.2	Introduction	1
1.3	Purpose	1
1.4	Planning Process	2
1.5	Engineering Process	3
1.6	Development Approvals	4
1.7	Agreements	4
1.8	Developer's Engineer	4
1.9	Utilities	5
1.10	Design Guidelines	5
2.0	SUBMISSION OF PLANS, REPORTS, AND STUDIES	6
2.1	Submission Procedure	6
2.2	Plans and Drawing Requirements	6
2.3	Plan-Profile Drawings	7
2.4	General Servicing Plan	9
2.5	Ministry of Environment, Conservation and Parks (MECP) Applications	9
2.6	Other Acceptances	10
2.7	Final Approval of Submission	10
2.8	Services for Individual Residential Lots	10
2.9	Easements	11
2.10	Preparation of Development Agreement	11
2.11	Requirements Prior to Commencement of Construction	12
2.12	As Recorded Drawings and Record Field Survey	12
3.0	ROADS	13
3.1	General	13
3.2	Clearing and Grubbing	14
3.3	Grading	14
3.4	Road Construction	14
3.5	Roadway Surface Asphalt	15
3.6	Curbs	15
3.7	Sidewalks	16
3.8	Accessibility	16
3.9	Turning Circles	16
3.10	Adjacent Roads	16
3.11	Driveway Entrances	16
3.12	Daylighting Requirements at Intersections	16
3.13	Location of Utilities	17
3.14	Community Mail Box Requirements	17
3.15	Snow Clearing	17
3.16	Other Requirements	18
4.0	STORM DRAINAGE/STORMWATER MANAGEMENT	18
4.1	Approval of Design and Plans	18

4.2	Stormwater Management Report	18
4.3	Connection to Municipal System.....	19
4.4	Design Criteria	19
4.5	Location	19
4.6	Sewer Pipe Material.....	20
4.7	Storm Sewer Construction	20
4.8	Maintenance Holes and Catch Basins	20
4.9	Private Drain Connections	21
5.0	SANITARY SEWERS	21
5.1	Approval of Plans.....	21
5.2	Location	22
5.3	Material	22
5.4	Design Standards	22
5.5	Sanitary Sewer Construction.....	22
5.6	House Connections.....	22
5.7	Grinder Pumps.....	23
5.8	Maintenance Holes	23
5.9	Testing and Flushing of Sewers.....	24
5.10	Completion and Acceptance	24
6.0	WATERMAINS	24
6.1	Approval of Plans.....	24
6.2	Locations.....	25
6.3	Design.....	25
6.4	Material and Size	25
6.5	Watermain Construction.....	28
6.6	Flushing, Testing and Disinfection	29
6.7	Completion and Acceptance	30
7.0	UTILITIES AND STREET LIGHTING	30
7.1	Telecommunications	30
7.2	Telecommunication Companies.....	30
7.3	Electrical	30
7.4	Gas Servicing.....	30
7.5	Street Lighting.....	30
8.0	LOT GRADING.....	31
9.0	PARKLAND AND LANDSCAPING	32
9.1	Parkland.....	32
9.2	Landscaping.....	32
9.3	Walkways & Beach Access.....	33
9.4	Trails	33
10.0	TRAFFIC AND STREET SIGNS.....	34
11.0	ASSET MANAGEMENT	34
12.0	PAYMENT TO DEVELOPERS	34
13.0	REVISIONS TO SERVICING GUIDELINES.....	34

LIST OF APPENDICES

Appendix "A" – Typical Cross Section for New, Urban Residential development

Appendix "B" – Typical Cross Sections, Various Types of Development

Appendix "C" – Stormwater Management Guidelines for Site Plans or Small Developments

Appendix "D" - Meter Box Connection for Multiple Residential Units for Typical Single Lot

MUNICIPALITY OF KINCARDINE MUNICIPAL DEVELOPMENT AND SERVICING GUIDELINES

1.0 GENERAL

1.1 Definitions

In these guidelines the following definitions shall apply:

“Municipality” shall mean Municipality of Kincardine.

“Developer” shall mean the Owner or party specifically named in a Development Agreement or in a Subdivision Agreement.

“Developer’s Engineer” shall mean professional engineer(s) licensed to practice in Ontario and shall be responsible for the preparation of drawings, specifications, reports and to act on behalf of the Developer in all technical aspects of the Development.

“Planner” shall mean the County and/or the Municipality’s Planner or their designate.

“Contractor” shall mean the firm of Contractors, the company of individuals acting as the Contractor and having entered into a contract with the Developer to construct the Development.

“Municipal Engineer” shall mean the municipal Director of Public Works and/or the engineer or engineering firm appointed as Municipal Engineer by the municipality.

1.2 Introduction

The design of all municipal services in the municipality is to be based upon the specifications and guidelines in effect at the time of acceptance. All plans are to be accepted before they are to be used for the construction of services. Such acceptance shall in no way relieve the Developer’s Engineer from providing an adequate and safe design.

1.3 Purpose

The purpose of this document is to aid in the standardization for the design of municipal servicing infrastructure for development in the Municipality of Kincardine. While these guidelines are primarily aimed at the expansion of residential development within the municipality, developers, builders, and the general public can use this document as a guide for developments created by consent, for individual site developments, or commercial and industrial areas.

The following two sections have been provided as a general overview of the procedures and steps involved in the completion of the planning and engineering processes related to development in the Municipality of Kincardine. These procedures are not written as a

detailed, step by step list, but rather as a general approach to the subdivision application, or site development process.

1.4 Planning Process

The Municipality should be contacted to arrange for a Pre-consultation meeting prior to initiating the planning process for any development. The Pre-consultation will assist to identify key planning issues as well as any major technical items including studies (i.e., traffic, noise, servicing, etc.) that may be required as part of the formal submission. The applicant may wish to have their consultant (planners, engineers, etc.) present at this initial meeting. It is anticipated that the following items would be discussed or reviewed:

- County will confirm the Official Plan designation and Zoning, identifying any Official Plan and Zoning amendments which may be required in addition to draft plan approval.
- The necessary application requirements including fees, supporting documents (contour plan, general plan of services, drainage plan, preliminary stormwater management plan, etc.), draft plan drawing requirements, and possible agreements that may be required.
- Timelines and potential scheduling for public meetings and Council meetings.

In the Municipality of Kincardine, land development (i.e., Subdivision and Condominiums) applications are to be submitted to the County of Bruce. Application packages and associated guides are available through the County which will provide an overview of the steps to make an application and obtain a decision on a specific proposal. Site Plan applications are to be submitted to the municipality.

Following submission of a complete application, it will be processed by Bruce County staff, who will circulate it to the municipality, community organizations, and required public bodies for comments, as well as to all property owners in the vicinity of the subject site. A Public Meeting must be held, usually in the community, to allow the public an opportunity to provide comments on the proposed plan of subdivision. The County will work with the applicant to address any agency and/or public concerns. A comprehensive report will be prepared by the County, along with draft plan conditions (based on input from agencies and the public) and presented to Council for review and decision. If Council accepts the application and the required appeal period lapses, the draft plan is approved.

As noted, there will be a number of conditions that must be satisfied before final approval of the development can be given. Among the conditions for subdivisions, site plans, and condominiums, there is usually a requirement that the owner enter into a development agreement with the Municipality regarding matters such as the construction of roads and servicing which will require the completion of engineered drawings to the standards contained herein.

1.5 Engineering Process

Following acceptance and approval of the draft plan, the developer shall proceed to the engineering phase of the development process which will include a number of submissions including preliminary and follow-up submissions as required. Prior to the commencement of the Engineering Design, the Developer's Engineer shall obtain copies of the Municipality's Development and Servicing Guidelines to familiarize themselves with the requirements of the development design in the Municipality.

The initial submission of engineering drawings shall be delivered to the Municipality and should include copies of the preliminary drawings and servicing (functional design) report(s). The initial submission of engineering drawings shall also contain a declaration from the Developer's Engineer showing that he/she has been retained to design and supervise the construction of the development according to the terms of the Development Agreement. The purpose of the initial submission is to review the general design concept prior to the Developer proceeding to detailed engineering. In some cases, this information may have been provided in conjunction with the Draft Plan process. The preliminary drawing and report should consider items such as existing conditions, road alignments, cross section details, railway crossings, parkland dedication, trunk sewers, storm water management and drainage, water distribution, lot grading, sewage conveyance, etc. This document becomes particularly important when servicing is to be phased in conjunction with the development plan. When a development is being phased the servicing report is to include details of how the phasing will occur and how infrastructure may be impacted by such phasing. The servicing report shall confirm that the servicing design does not limit future developments areas. Comments may be provided related to any issues that are evident and the Developer will be asked to update the Engineering Drawings accordingly.

The Developer may be required to submit hydrogeological, hydrology, traffic, acoustical, geotechnical, archaeological, biological or other studies. Appropriate engineering or other consultants shall be retained to complete these reports as part of the applications and submissions required. The Developer's Planner and/or Engineer shall consider future adjacent land uses, and all design and layout of services shall incorporate considerations with respect to future servicing, grading and drainage issues on the adjacent lands. Upon completion of designs and submissions, sufficient copies of preliminary design briefs, agency approval submissions and all final drawings and reports shall be submitted to the Municipality for review by the Municipality and their Engineer.

Submissions are to be made until the Engineering Drawings, design and reports, are acceptable to the Municipality of Kincardine and the Municipal Engineer.

Additional details related to drawing requirements and approvals are provided in later sections of this document.

1.6 Development Approvals

Depending on the nature and location of the development proposal within the Municipality the developer may be required to obtain additional approvals from a number of agencies including, but not limited to the following:

- a) The Municipality of Kincardine and the Municipality's Engineer
- b) The Ministry of the Environment, Conservation and Parks (MECP)
- c) The Ministry of Transportation (MTO)
- d) The Ministry of Natural Resources and Forestry (MNRF)
- e) The Department of Fisheries and Oceans (DFO)
- f) The County of Bruce
- g) The Grey Bruce Health Unit (GBHU)
- h) The Saugeen Valley Conservation Authority (SVCA)
- i) The Saugeen Valley Source Protection Authority
- j) The Minister of Heritage, Sport, Tourism and Culture
- k) The Kincardine Accessibility Advisory Committee

It is the responsibility of the Developer to provide the municipality with written documentation detailing its application to the various authorities and copies of approval documents from these regulatory agencies.

1.7 Agreements

As noted, the developer shall be required to enter into a Subdivision or Development Agreement with the Municipality. A standard form of that agreement is available from the Municipality for a developer's review. Certain fees, deposits, and charges will apply and are outlined within that document. Information regarding the preparation of the Development Agreement is provided in Section 2.10 of this document.

1.8 Developer's Engineer

The developer shall employ Engineers registered with Professional Engineers' Ontario to design all of the services, prepare plans and specifications, and provide construction review and inspection of all works.

The services shall include the following:

- Preparation of functional reports as may be required through the draft plan approval process
- Preparation of designs
- Preparation of drawings for approval purposes and construction
- Preparation of necessary contracts and specification documents
- Preparation of necessary approval documents in conjunction with the regulatory agencies
- Provision of contract administration, and full time construction review of all Municipal facilities

- Maintenance of records of construction and upon completion, the provision of As Recorded drawings in suitable digital format to the Municipality
- Provision of certification to the Municipality the works have been constructed in general conformance with the approved plans and specifications
- To act as a representative of the developer in all matters pertaining to the construction
- To provide coordination of the scheduling to comply with timing provisions for inspections and testing of the works
- To provide certification of the installation of services was in conformance to said plans and specifications, such certification should be in a form acceptable to the Municipality's solicitor and the Municipality's Engineer

The Developer's Engineer shall provide evidence of professional liability insurance from their insurer in the amount of not less than five million dollars per occurrence prior to the review of any reports or briefs by the Municipality of Kincardine. Insurance requirements shall be as detailed in the Municipality's Standard Development Agreement.

1.9 Utilities

The Developer shall coordinate the design and installation of all utilities including electrical, telecommunications (telephone, internet, TV) and gas. These utilities shall be installed within the road allowance in accordance with the typical cross section attached as Appendix "A" to this document. The Developer shall provide documentation to the Municipality that it has contacted all telecommunications providers and advised them they will have access to servicing in the Development. For any Development in the Municipality of Kincardine the Developer shall insure that Bruce Telecom is provided access to install their utilities. The Developer will be asked at times in the development process to provide confirmation from the utility companies that the appropriate arrangements have been made for installation and upon completion of said installation of the utilities, provide to the Municipality a notice of completion by said companies.

1.10 Design Guidelines

The guidelines that follow should be adhered to wherever possible. It is acknowledged that on occasion unique and special circumstances occur and minor deviations may be required from the guidelines. These deviations shall only be made through consultation with the Director of Public Works and the Municipal Engineer. Further, the Municipality reserves the right to require compliance to a higher standard on occasions where warranted (dependent upon the specific details of any development). Further, the Municipality may require higher standards in areas of higher density developments, arterial or collector roads, or heavy industrial traffic.

These guidelines should be read in conjunction with the standard engineering practice as established by the MECP and MTO together with regulations, the current drinking water license, current municipal sewage collection ECA, current municipal stormwater management system ECA, design manuals and guidelines of the Municipal Engineers'

Association. Unless superseded by the Municipality's Development and Servicing Guidelines specific standard drawings and specifications from the Ontario Provincial Standards Specifications and Ontario Provincial Standard Drawings shall be used as reference for individual details (OPSS, OPSD).

During the design phase, discussion and consideration shall be given to the recommendations contained within the Kincardine Master Cycling Plan.

2.0 SUBMISSION OF PLANS, REPORTS, AND STUDIES

2.1 Submission Procedure

All submissions for approval shall be forwarded to the Municipality of Kincardine to the attention of the Development Services Planning Coordinator of the Municipality in sufficient quantities as may be required for distribution. The Planning Coordinator will distribute said plans to public works, CBO, planner, Municipality's Engineer, fire department, etc. All comments and re-submissions shall proceed through the Planning Co-ordinator.

Drawing submissions shall include but not be limited to:

- a) Plan and profile.
- b) General Servicing Plan
- c) Typical cross section(s).
- d) Typical lot grading sections.
- e) Lot grading drawings.
- f) Typical swale details.
- g) Geotechnical report information.
- h) Specific structure and erosion protection and control details.
- i) Details with respect to stormwater management and associated facilities.
- j) Details of water pumping and storage facilities, sewage pumping facilities and any other special facility required for the type of development proposed.
- k) Details of all installations not covered and noted by standard OPSD drawings.
- l) Such other environmental reports as may have been prepared as part of the application process.

2.2 Plans and Drawing Requirements

Drawings must be prepared in a digital format, which is compatible with the current version of AutoCAD, for all new development within the Municipality. The digital files and drawings, including those digital plans showing details of special structures, details, etc., shall be prepared by the Developer's Engineer and provided to the Municipality as a permanent record prior to the Final Acceptance of services required to be provided by the Developer. All digital files are to be geographically referenced in a format suitable for insertion into a geographic information system.

The following standards shall be adhered to in preparation of these drawings:

- (a) Existing services shall be shown as dotted or dashed lines while proposed services shall be shown as solid lines.
- (b) All elevations shown on the drawings are to be of geodetic origin.
- (c) Drawings shall be of a consistent size – 594 mm x 841 mm.
- (d) Scales shall be as follows for drawings:-

General Servicing Plan Scale Ratio	- 1:1000
Plan-Profile Drawings Horizontal	- 1:500
Vertical	- 1:50

Ratios shall be shown on all drawings.
- (e) A standard title block placed in the lower right corner of all drawings shall be used in which revisions are clearly dated and displayed, and in which the Municipality is named. A title sheet containing a drawing index shall be provided for each drawing set. A key plan at a suitable scale shall be displayed on all plan and profile drawings as well as the General Servicing Plan. The area covered by each specific drawing shall be identified in the key plan.
- (f) All engineering drawings shall be stamped and dated by the Developer's Engineer prior to issuance for tender.
- (g) Upon completion of the works, As Recorded drawings, as outlined elsewhere in these specifications, shall be submitted prior to acceptance of the services. These drawings shall be comprised of the original drawings that were issued for construction, amended to incorporate any changes implemented during construction.

2.3 Plan-Profile Drawings

Plan-Profile drawings are required for all roads, blocks and easements where services are proposed, for all outfalls, and for all boundary roadways abutting the development. The following standards shall be adhered to in the preparation of Plan-Profile drawings:

- (a) All profiles must be drawn with reference to the geodetic datum (NAD83 – Zone 17) noted on each drawing. All drawings must contain a complete legend.
- (b) Drawings are to be prepared so that each street can be filed separately. The street names must be identified on the plan portion of the drawings.
- (c) In general, East-West streets shall have zero chainage at their westerly limits and North-South streets shall have zero chainage at their southerly limits. Chainages shall increase from left to right. On the plan portion of each drawing the centerline of construction shall be noted with chainage in 20 metre increments. Chainage for the centerline of construction as well as the chainages for vertical curves (i.e. beginning, end, and apex points) shall be noted on the profile portion of each drawing.

-
- (d) When the plan must be broken because of curvature, etc., the profile shall be broken as well, so that, insofar as possible, chainage points in plan and profile will coincide vertically. When a street must be displayed on more than one drawing due to its length, match lines shall be used with no overlapping of information.
 - (e) The beginnings and ends of curves must be shown on the plan and profile with the radius of curvature shown on the plan. Chainages of points of curvature shall be calculated.
 - (f) The chainage and names of intersecting streets shall be shown in plan and profile, and the reference drawing numbers for these streets and for any match lines shall be shown on all applicable drawings. The drawings shall show clearly the proposed profiles, road widths and cross-sections, ditches, ditch gradients, curb gradients if different from the proposed services, north arrow and limits of the proposed work. The plan shall show any required off-street drainage and separate profiles shall be prepared for drainage easements. All detail for intersecting streets including grades must be shown for a distance of 50 metres from the intersection of the intersecting street. All street lines, for drainage or services, shall be shown and all easements.
 - (g) Plan-Profile drawings shall identify road allowances, lot and block frontages, easements, and reserves. Curb, gutter, and sidewalk are to be shown and dimensioned on the plan portion of the drawings.
 - (h) Storm and sanitary sewers shall be drawn in both plan and profile. In profile, the diameter of the sewer shall be drawn to scale. On the plan portion, sewers shall be described by size, type, and direction of flow. On the profile portion, the length, grade, pipe material and class, usage (storm or sanitary) and bedding type shall be identified.
 - (i) Structures associated with sewers (i.e. maintenance holes, catch basins) shall be numbered and drawn on both the plan and profile portions. On the profile portion, the number, offset, size, invert elevations, and applicable OPSD shall be identified for each structure. Safety platforms or drop connections shall be noted on the profile portion where applicable. Top of grate elevations shall be specified for rear lot catch basins.
 - (j) Ditch profiles and grades shall be shown.
 - (k) Watermains, hydrants, and valves shall be drawn on the plan portion of the drawing. On the profile portion, the diameter of the watermain shall be drawn to scale.
 - (l) Water and sanitary service connections shall be shown in the plan portion of each drawing.

- (m) The original and proposed ground profiles shall be plotted. Proposed vertical curves shall be defined by all relevant data (K value, grade, etc.). Proposed roadway profiles shall be displayed sufficiently beyond the limits of construction to confirm the feasibility of future extensions.
- (n) Details of gutter grades for cul-de-sacs and crescents shall be provided on the plan portion as a separate detail at a scale of 1:100.
- (o) Existing utilities and services shall be shown in plan.
- (p) The following additional information shall be shown in plan:
 - Curb radii at all intersections;
 - Location of luminaire poles and transformers;
 - Location and type for all street name and traffic control signs
 - Any special notes related to construction procedures or requirements.

2.4 General Servicing Plan

A copy of the General Servicing Plan shall be submitted to the Municipality identifying the proposed locations of telecommunications, electrical servicing, and gas mains, as well as watermains, storm sewers and sanitary sewers. All locations must be established and resolved by the Developer's Engineer in conjunction with the utility companies and following the locations shown on the Municipality's Typical Cross-Section. The drawing should also display lot and street boundaries and dimensions in accordance with the Registered Plan for the area. Geodetic (with reference to the NAD83 vertical datum) and site benchmarks should also be identified. If applicable, flood lines specified by the local Conservation Authority should be displayed.

2.5 Ministry of Environment, Conservation and Parks (MECP) Applications

After the engineering design and drawings are accepted by the Municipality, one complete set of engineering drawings and three copies of the Ministry of Environment, Conservation and Parks Environmental Compliance Approval (ECA) forms for storm sewer, stormwater management, and sanitary sewer approvals (where required) shall be submitted to the Municipality. These copies will be signed by the Municipality and then returned to the Developer's Engineer who will then make application to the Ministry of the Environment, Conservation and Parks for acceptance under the Ontario Water Resources Act. When required, air, noise, and water related applications are also be provided for signing.

For most additions and alterations to the municipal water distribution system, where an ECA is not required, the Developer's Engineer shall provide a complete MECP Form 1 – Record of Watermains, and all supporting information and calculations.

For most additions and alterations to the municipal sewage collection system, where an ECA is not required, the Developer's Engineer shall provide a complete MECP Form SS1 - Record of Future Alteration Authorized for Separate Sewers/Nominally Separate

Sewers/Forcemains and where needed, a complete Form SS2 - Record of Future Alteration Authorized for Components of the Municipal Sewage Collection System, with all supporting information and calculations.

For most additions and alterations to the municipal stormwater management system, where an ECA is not required, the Developer's Engineer shall provide a complete MECF Form SW1 - Record of Future Alteration Authorized for Storm Sewers/Ditches/Culverts and where needed, a complete Form SW2 - Record of Future Alteration Authorized for Stormwater Management Facilities, with all supporting information and calculations.

2.6 Other Acceptances

The Developer's Engineer is required to make all submissions and representations necessary to obtain acceptances from all other authorities affected (Ministry of Natural Resources and Forestry, Ministry of Transportation, Conservation Authorities, Source Water Protection, Canada Post Corporation, Fire Marshall, Medical Officer of Health, etc.). The Municipality shall be kept informed of the progress of these submissions by way of copies of all correspondence.

2.7 Final Approval of Submission

After the Municipality is satisfied that they have completed their review of submission of drawings and have documentation from the Developer or their Engineer that all other regulatory agencies have been satisfied with their approval submissions, the Developer shall submit to the Municipality final copies of drawings and specifications in quantities the Municipality may determine sufficient which shall include all details required by the Municipality and the approval agencies. Any changes subsequent to this submission which may be proposed by the Developer or their engineer must be resubmitted to the Municipality for review and for their approval prior to such changes being made in the installation of services. If one year has passed since the date of the acceptance of the drawings by the Municipality and the Developer has not yet entered into a Development Agreement with the Municipality, the Municipal Engineer reserves the right to revoke any or all acceptances related to the engineering drawings.

2.8 Services for Individual Residential Lots

Services for individual residential lots or units shall generally be as follows:

- a) Sanitary service shall be installed 1.5 m to the left of centre of each lot
- b) Water services shall be installed at the centre of each lot
- c) Private drain connections shall be installed 1.5 m to the right of centre of each lot
- d) Telephone, cable TV and electrical services shall be installed in a common trench
- e) Driveways shall be located on the opposite side of the lot from pad mount transformers, hydrants, street lights, or perpendicular intersecting roads

2.9 Easements

Where buried services, utilities, channels, overland flow routes, etc., are placed outside the road allowance, permanent easements will be required. The widths of the easements shall be determined through consultation with the Municipality. In general, the buried infrastructure shall be placed in the centre of the easement.

2.10 Preparation of Development Agreement

The draft of the Development Agreement will be prepared by the Municipality. The Developer's Engineer shall prepare a servicing cost estimate for review and inclusion in the agreement related to securities. The Municipality must be in a position to clear all conditions of the Draft Plan Acceptance prior to the preparation of the draft Development Agreement Schedules. The following information must be provided by the Developer's Engineer to the Municipality prior to the preparation of the draft Development Agreement Schedules:

- a) MECP certificates of acceptance for all the services to be constructed if available. If necessary, the Developer's Engineer shall provide a completed MECP Form 1 for watermains, MECP Form SS1 and/or SS2 for sanitary and MECP Form SW1 and/or SW2 for storm.
- b) The name of the person and/or company with whom the Development Agreement will be executed.
- c) The name, address and telephone number of the developer's lawyer.
- d) Four copies of the Reference Plan.
- e) Four copies of the Legal Description based on the Reference Plan, including but not limited to, easements, reserves and daylighting.
- f) Four copies of the proposed final plan for future registration complete with all the pertinent information as required by the registry office. The plan shall show all required lots, blocks, and easements.
- g) Three copies of the accepted engineering drawings.
- h) A detailed cost estimate of all services to be constructed. This estimate will form the basis for calculation of security to be posted for this development. It shall include:
 1. Detailed cost of services;
 2. Cost of underground electrical distribution and street lighting (where not part of a separate agreement with the utility);
 3. All miscellaneous expenditures;
 4. Allowances for contingencies, engineering, and HST.
- i) Proposed timetable for construction of services reflecting phasing.
- j) Proposed landscaping plans where necessary or required.

2.11 Requirements Prior to Commencement of Construction

Following signing of the agreement, receipt of the insurance certificate, receipt of security deposit (i.e., Letter of Credit), and at least two weeks prior to the commencement of construction, the Developer's Engineer shall submit the following information to the Municipality for acceptance:

- Two sets of construction specifications;
- A list containing the Contractor, subcontractors and the Contractor's material suppliers;
- A copy of the signed contract tender complete with prices;
- Proposed disposal sites;
- Insurance documents;
- Project schedules;
- Spills Action plan;
- Any other information as required by the Municipal Engineer or as specified in the Development Agreement.

In addition to the above items, the Developer's Engineer must provide confirmation that all recommendations of the Erosion Control plan are implemented. The Developer's Engineer must schedule a pre-construction meeting and provide sufficient notice of this meeting to the Municipality.

2.12 As Recorded Drawings and Record Field Survey

The Developer's Engineer shall retain a record of all revisions to the design that were implemented during construction. These "record revisions" shall be based on a final survey of the development. The final survey shall include a check of the following items:

- Location and invert elevations of all sewer maintenance holes
- Distances between all sewer maintenance holes
- Location of all roadway catch basins
- Location, rim and invert elevations for all rear yard and lot catch basins
- Location and ties to all valve boxes, chambers, hydrants and other watermain appurtenances
- Road centreline elevations
- Site benchmarks

The original drawings shall be revised to incorporate all changes and variances found during the final survey and to provide ties and additional information to readily locate all underground services. These new amended drawings shall constitute the As Recorded drawing set.

The As Recorded drawings shall display all sewer and road grades recalculated to two decimal places. Pipe sizes and materials shall be shown for all sanitary sewer, storm

sewer and watermain infrastructure. All street names, lot numbering and block identification shall be checked against the Registered Plan and corrected if necessary. An As Recorded revision note shall be placed on all drawings in the revision block.

At any time up to two years after Final Acceptance of the development, the Municipal Engineer may return the As Recorded drawings to the Developer's Engineer for rechecking and further revision if discrepancies are found. The Developer's Engineer shall be required to explain in writing any major difference between the design and the As Recorded data to provide verification that the alteration does not adversely affect the function of the development services.

All As Recorded drawings must be submitted to the Municipality in PDF, georeferenced AutoCAD and where possible GIS shapefile format.

A paper and electronic copy of the As Recorded drawings must be submitted to the Municipality for review before Stage 2 "Preliminary Acceptance" of the development will be given.

The Development Agreement shall be referred to for the definition of Stage 2 "Preliminary Acceptance".

3.0 ROADS

3.1 General

All local roadways for residential development shall be designed and constructed to the urban standard and the typical cross section shown in Appendix "A" to this document. Road allowances shall be a minimum of 20 metres wide. The edge of the roadway paved surface shall have a minimum radius of 9 metres at intersections. Access roads not owned by the Municipality, leading to the area of the development, shall be constructed and maintained to a standard equal to the standards for roadways within the development. On all streets, horizontal and vertical sight distances and vertical curves shall meet Ministry of Transportation (M.T.O.) Geometric Design Guidelines.

Road allowances on cul-de-sacs are to have a minimum radius of 20 metres. Edge of pavement radius on cul-de-sacs are to be a minimum of 13 metres.

Minimum road asphalt width shall be 8.5 metres. The finished roadways shall have a crossfall of 2% from the centerline to each curb line.

Should the development require the construction of arterial or collector roads, the Municipality will establish design widths for that section of road if required. Roadway pavement and road allowance widths for industrial, commercial, or rural development shall be established in consultation with the Municipality.

A qualified geotechnical firm shall be engaged by the Developer's Engineer to confirm the suitability of the minimum pavement designs contained in these guidelines for use in the Development, or to recommend a higher standard if required. The same

geotechnical firm shall be retained by the Developer's Engineer to carry out field testing during construction to verify the design.

Copies of all test results and proposed road designs shall be submitted with the engineering drawings. Testing and acceptance of all granular materials at the designated pits prior to placement and subsequent in-situ verification tests shall also be performed by the Developer's geotechnical firm.

Prior to the placement of asphalt pavement, the Developer's Engineer must submit to the Municipal Engineer for acceptance, the asphalt pavement mix designs.

3.2 Clearing and Grubbing

Trees shall be removed so that the specifications for sight distances, grading, ditching, etc., may be met. All stumps, logs, brush, boulders, debris, etc. shall be removed from the street allowance. Unless noted otherwise, all healthy trees not obstructing visibility or installation of services shall be preserved. The Municipal Engineer may give permission to leave trees on the street allowance, providing that they are situated more than 1.5 metres behind the curb.

Developer to review local bylaws and policies regarding tree removal, obtain permit(s) as needed.

3.3 Grading

A 2 metre boulevard area behind the curbs and/or sidewalk (as applicable) shall be graded at a minimum of 2% and maximum of 5% towards the curbs. Where the proposed road extends through areas of cut and fill, the area from the edge of the road boulevard to the street line shall be graded with a side slope not exceeding a slope of 3 metres horizontal to 1 metre vertical to meet the original ground. All side sloped ditches and boulevards to the street line shall be protected with nursery sod over a minimum depth of 100 mm of topsoil.

In all cases, topsoil shall be stripped for the complete width of the road allowance and stockpiled at locations accepted by the Municipal Engineer. Rough grading shall be done to bring the travelled portion of the road to the necessary grade and in conformity with the cross-section shown on the drawings. All subgrade material shall be compacted to 95 percent Standard Proctor Density prior to any application of granular base course materials.

Rough grading of all lots and easements must be properly shaped to ensure suitable drainage.

3.4 Road Construction

All road construction shall conform to applicable standards of the Ontario Provincial Standard Specifications (OPSS) and the Ontario Provincial Standard Drawings (OPSD). The granular road base shall consist of a bottom course of 300 mm minimum depth

consolidated Granular “B” full width across the roadway and a top course of 150 mm of Granular “A” full width between concrete curbs. The granular materials shall be spread in layers of 150 mm maximum compacted depths, and each layer shall be thoroughly compacted. During and between construction seasons, the granular base shall be maintained suitable for vehicle and pedestrian traffic, including dust control by calcium chloride and renewed if required to the satisfaction of the Municipal Engineer.

Road subdrains shall be provided as required in accordance with OPSS 405.05 and amended to accept only polyethylene Big “O” Boss 2000 or equivalent. The subdrain shall include filter wrap (non-woven type) in accordance with OPSS 1860. The Municipality reserves the right to require video inspection of subdrains prior to acceptance.

3.5 Roadway Surface Asphalt

As soon as the granular base has been completed, it shall be thoroughly compacted and shaped and the base course of asphalt placed (if practical and if with approval from the Municipality). The base course shall consist of 50 mm minimum thickness of HL-4 Base Course Asphalt. Following at least one year from the date of placement of the base asphalt, the Developer shall arrange an inspection with the Municipality to discuss any remedial work that may be required prior to placing the surface coat of asphalt. Not sooner than one year following the completion of any remedial works and as dictated by the Development Agreement shall the surface coat of asphalt be placed consisting of 40 mm minimum thickness of HL-3 Surface Course Asphalt. Asphalt work shall conform in all respects to OPSS 310.

All joints perpendicular to the centerline or at any patches shall be lapped a minimum of 0.5 metres. Temporary ramping, pending completion of the top coat shall extend a minimum of 1.0 m. onto the base coat of asphalt.

3.6 Curbs

Concrete curb and gutter, of cross-section approved by the Municipal Engineer, shall be provided along all edges of paved roadway surface. Terminations at the limits of the subdivision shall be either joined to existing concrete curbs or rounded to reduce hazard to traffic. Construction shall conform to OPSS 353.

Driveway depressions shall be formed in the curb according to OPSD 351.010. The maximum width shall be 6.0 m. If a driveway location cannot be determined at the time of pouring, a full section of curb and gutter shall be poured continuously. When the driveway location is determined, a driveway depression can be cut with a curb cutting machine providing the section to be cut is free from cracks and other defects. The Municipality reserves the right to request semi-mountable curb and gutter where they deem it appropriate. All curb and gutter is to be protected from damage by heavy equipment and vehicles. Two stage curb is not permitted.

3.7 Sidewalks

A 1.5 metre sidewalk shall be constructed on one side (minimum) of each street within the development. Sidewalks shall have a minimum depth of 125 mm and shall be bedded in granular in accordance with the current OPS standard details. On arterial or collector roads, sidewalk shall be placed on both sides of the road. The sidewalks shall be increased in thickness from 125mm to 150mm at all driveway locations, and 200mm for commercial or industrial driveways. Granular depth shall be 150mm minimum or increased to the same depth as the sidewalk or drive where installed thicker. Tactile plates shall be placed at all road crossings. The municipality shall be consulted on their current standard.

Sidewalks shall be placed prior to construction of asphalt or concrete driveways.

3.8 Accessibility

As part of construction of any concrete curb and gutter, sidewalks or other surface structures, the Developer will be responsible for construction of all Works in accordance with the Municipality's and the Province of Ontario's current accessibility standards and regulations to provide full access where possible, to all individuals in the community.

3.9 Turning Circles

Where construction is phased, the Municipality may require the installation of temporary turning circles. These turning circles will be constructed in accordance with the requirements for cul-de-sacs in Section 3.1 of this Schedule. Temporary cul-de-sacs shall be paved and curb and gutter shall be provided when needed to contain surface water and direct it to the storm sewers.

3.10 Adjacent Roads

Whenever a development abuts adjacent roads, improvements to those roads and the installation of all municipal services shall extend to the limit of the property owned by the Developer.

3.11 Driveway Entrances

Driveway entrances shall be constructed to the property or to the edge of sidewalk. Entrances shall have a consolidated base constructed of 300 mm minimum depth of Granular "B" and 150 mm minimum depth of Granular "A". All entrances shall be hard surface (asphalt, concrete, or similar material). All entrances shall be completed in accordance with the current OPS standard details.

3.12 Daylighting Requirements at Intersections

Where deemed necessary by the Municipality, daylighting at intersection quadrants shall be included in the road allowances to provide for uniform boulevard widths. When

required, daylighting details (location, and size) shall be included on the proposed plan for Registration and on all engineering drawings.

3.13 Location of Utilities

The location of utilities within the road allowance shall be as detailed on the Municipality's standard drawings. Utility drawings shall be submitted to the Municipal Engineer for acceptance of the proposed utility locations. All utility wiring is to be housed underground or direct buried. Hydro transformers are to be housed in suitable enclosures and mounted on transformer pads installed at the final elevation of the adjacent ground. The location of transformer pads shall be as detailed on the Municipality's standard drawing and are typically to be located in the opposite boulevard of the sidewalk. Telecommunications junction boxes may be mounted at the surface in accepted standard enclosures.

3.14 Community Mail Box Requirements

Community mail centres and/or site individual super mail boxes shall be placed in locations accepted by the Municipality. Community mail centres shall be constructed centrally and suitably located in consultation with the Canada Post Corporation. The design of the community mail centre must incorporate such criteria as pedestrian safety, traffic flow and aesthetics. The Municipality may require the developer to furnish the following amenities within the community mail centre:

- Park benches
- Fencing
- Litter containers
- Landscaping
- Pedestrian lighting
- Concrete pad or interlocking stone surface
- Architectural controlled kiosks
- Adjacent car bays parallel to the travelled portion of the roadway.

All details associated with the community mail centres or super mail boxes shall be identified on the Engineering Drawings and will be subject to review by the Municipality. The Developer shall be responsible for constructing community mail centres within residential developments, prior to the issuance of the first building permit.

The acceptance of Canada Post Corporation with respect to location of community mail centres and/or site individual super mail boxes will be required prior to the acceptance of the Engineering Drawings by the Municipal Engineer.

3.15 Snow Clearing

Snow clearing operations prior to "Final Acceptance" shall be carried out by the Developer.

3.16 Other Requirements

Whenever it is necessary to cut through an existing Municipal road, the Contractor will be responsible to obtain a permit from the Municipality. The placement and compaction of the backfill material and the restoration of the surface pavement shall be done in accordance with the standard and specifications in effect at that time.

Before making detours, permission is required from the Municipality's Public Works Department. Where the road is not part of the Municipality's road system, acceptance from the appropriate road authority will also be necessary. In all cases, the fire, police departments, school bus companies and ambulance service must be notified by the Developer or its Contractor.

All work will be done in accordance with ordinances and By-laws of the Municipality.

4.0 STORM DRAINAGE/STORMWATER MANAGEMENT

4.1 Approval of Design and Plans

Storm sewers shall be provided to serve the whole of the development. Drawings shall consist of an overall plan, a plan and profile of each storm sewer, drawn to the same scale as the roads, pipe bedding, Maintenance Holes, and other appurtenances. Design (including all drawings and calculations) of the proposed works must be submitted to the Municipal Engineer and applicable government agencies for approval. For most additions and alterations to the municipal stormwater management system, where an ECA is not required, the Developer's Engineer shall provide a complete MECP Form SW1 - Record of Future Alteration Authorized for Storm Sewers/Ditches/Culverts and where needed, a complete Form SW2 - Record of Future Alteration Authorized for Stormwater Management Facilities, with all supporting information and calculations.

If required, plans of the entire system shall be submitted to the Ministry of the Environment, Conservation and Parks for approval. Approval for construction will not be given until all Environmental Compliance Certificates have been received from the Ministry of the Environment, Conservation and Parks and all other applicable government agency approvals have been received.

Developer's will be responsible to follow the requirements set out in the Municipality of Kincardine's Consolidated Linear Infrastructure Environmental Compliance Approval, included the signage requirement for all stormwater facilities (including but not limited to ponds, outlets and overflow areas). The Municipality will provide the signage and invoice the developer for the cost of signage.

4.2 Stormwater Management Report

A Stormwater Management Report setting out the existing and proposed drainage pattern shall be submitted to and approved by the Municipal Engineer, the Saugeen Valley Conservation Authority and the Ministry of the Environment, Conservation and

Parks. Should the development be of a size or location that the Conservation Authority has no requirement to regulate the stormwater management criteria, or in the event that specific design details are not provided by the Conservation Authority, the guidelines in Appendix “C” shall apply.

The stormwater management requirements within the Municipality shall be those of the local Conservation Authority or as listed below in the general requirements:

- Quality and quantity control – as dictated by the local Conservation Authority and/or the MECP. Quantity control shall restrict post-development runoff flows to pre-development flows between the 5 and 100 year / Regional storm events
- The design storm for the minor systems shall be the 5 year storm for local storm sewers and the 10 year storm for trunk facilities. The major system shall be designed to convey the Regional storm.
- Sediment and erosion control measures associated with the stormwater management requirements shall be identified on the drawings for works to be included during the construction and for permanent measures.

4.3 Connection to Municipal System

The storm sewers shall be connected to the Municipal storm sewer system (where feasible) or discharged to a natural watercourse as approved by the Municipality, Conservation Authority, and the Ministry of the Environment and Climate Change.

4.4 Design Criteria

The stormwater management system shall be designed by using MIDUSS (current version) or an alternate approved hydrologic model. The Developer's Engineer shall consult the Conservation Authority as to the appropriate storm distribution and duration to be used. The Developer's Engineer shall advise the Municipal Engineer in writing as to the Authority's requirements. The Developer shall ensure that the Municipality is aware of any requirements that the Conservation Authority may have so that they can be reviewed, discussed, and revised should the Municipality deem it necessary. The design of the stormwater management system shall be in accordance with the following:

- Appendix “C”, Section A – Storm Drainage and Stormwater Management;
- Latest version of the “Stormwater Management Practices, Planning and Design Manual” and “Design Criteria for Sanitary Sewers, Storm Sewers and Forcemains for Alternations Authorized under Environmental Compliance Approval”, as prepared by the Ministry of the Environment and Climate Change.

4.5 Location

The storm sewer shall be located under the gutter line, with lateral connections to catch basins located within the curbing.

4.6 Sewer Pipe Material

Sewer pipe material shall be:

- (a) Concrete Sewer Pipe (Rigid)
 - 150 mm to 250 mm non-reinforced Class 3 – CSA certified to A257.1
 - 300 mm or greater reinforced as specified in the tender form – CSA certified to A257.2
- (b) Polyvinyl Chloride (PVC) Pipe (Flexible)
 - Class SDR 35 or Class V (320 kPa)
 - Annular ribbed profile for ripped pipe
- (c) Polyethylene Sewer Pipe (Flexible) – CSA certified Sewer Class to B 182.6
 - 150 mm to 750 mm
 - smooth inner wall, annular corrugated profile (320 kPa), 15 PSI bell and spigot joints shall have elastomeric gaskets (CSA certified to B 182.6)

The minimum size, including catch basin leads, shall be 300 mm. The Municipality may require a larger storm sewer size on parts of the subdivision than required for the subdivision alone.

4.7 Storm Sewer Construction

Storm sewer construction and pipe bedding shall conform to the requirements of the Ontario Provincial Standard Specifications for sewer construction. Pipes shall be bedded in approved granular materials.

Catch basin leads shall be connected to the main sewer with a maintenance hole except where the main sewer size exceeds 450 mm diameter, in which case the lead can be connected directly to the main sewer using a factory manufactured “Tee”.

4.8 Maintenance Holes and Catch Basins

Concrete Maintenance holes shall be provided at all changes in direction of the sewer and at all street intersections, with maximum spacing on straight runs as noted:

Sewer Diameter (mm)	Maximum Spacing (m)
250 to 975	110
1050 to 1350	130
1500 to 1650	160
1800 and above	305

Maintenance holes shall be 1200 mm diameter or larger, conforming to OPSD Series 700. Benching shall be provided in all maintenance holes. Catch basin maintenance holes shall contain a sump or minimum depth of 300 mm below lowest invert on sewers up to and including 600 mm diameter.

Frames and covers shall be OPSD 401.01 Type A, or approved equal, set on not less than three (3) layers nor more than six (6) layers modoloc pre-cast units, which shall be parged on the outside face. Adjustment units shall conform to OPSD 704.010.

Catch basins shall be provided on both sides of the street at all low areas with the maximum spacing as noted:

Road Gradient (%)	Maximum Spacing (m)
0 to 3	110
3.1 to 4.5	90
Over 4.5	75

Catch basins shall be provided on both sides of the street at all low areas but no further apart than 90 m. Catch basins for depth up to 2 m from ground level to invert shall be 600 mm square concrete conforming to OPSD 705.01. For greater depths, catch basins-maintenance holes shall be used conforming to OPSD 701.03. Frame and grates shall be OPSD 400.110.

4.9 Private Drain Connections

Private storm service connections (PDC) are required for all lots or units in the new development. PDC's shall be installed at a minimum depth of 1.5 m. Cleanouts shall be provided at the property line with cast iron caps clearly marked "Storm". All buildings shall have their footing drains connected to a sump pump with discharge to these private drain connections. No eavestrough connections will be allowed.

The minimum diameter of PDC shall be 150mm and service lateral pipe material colour shall be white. Colour coding method includes pipe colour, wrapping, demarcation tape or stenciling. The top of the cleanout shall be installed flush with the ground surface 300 mm outside the lot line complete with a bolted cap (Malcolm or approved equal), attached using a PVC fitting.

5.0 SANITARY SEWERS

5.1 Approval of Plans

Plans of the entire system shall be submitted to the Ministry of the Environment, Conservation and Parks for approval following acceptance of the plan by the Municipal Engineer. This submission shall consist of an overall plan, a plan and profile of each main sewer drawn to the same scale as the roads, together with typical details of house service connections, pipe bedding, Maintenance Hole covers, all special bends and connections and other appurtenances. Approval for construction will not be given until the Certificate of Approval for all infrastructure and facilities has been received from the Ministry of the Environment, Conservation and Parks.

For most additions and alterations to the municipal sewage collection system, where an ECA is not required, the Developer's Engineer shall provide a complete MECF Form

SS1 - Record of Future Alteration Authorized for Separate Sewers/Nominally Separate Sewers/Forcemains and where needed, a complete Form SS2 - Record of Future Alteration Authorized for Components of the Municipal Sewage Collection System, with all supporting information and calculations.

Developers will be responsible to follow the requirements set out in the Municipality of Kincardine's Consolidated Linear Infrastructure Environmental Compliance Approval.

5.2 Location

The main sewers shall be located along the centre of the street allowance. House connections shall terminate at the property line for each lot.

5.3 Material

Main sewers shall be P.V.C. (SDR35) or approved alternate. House connections shall be P.V.C. (SDR28) or approved alternate. All joints shall be of the rubber gasket type as approved by the Municipal Engineer. Approved caps shall be provided for service lateral terminations.

5.4 Design Standards

Sanitary service shall be designed in accordance with current MECP design guidelines.

The minimum size for main sewers shall be 200 mm diameter. House connections shall be a minimum of 125 mm in diameter. For multiple dwelling, industrial or commercial buildings, the service connections shall be sized to accommodate the flow.

Unless otherwise specified, flows for residential units shall be designed for 450 L/cap/day and inflow/infiltration allowances shall be 0.28 L/s/ha.

Sanitary sewer capacity shall be design to normal design parameter of:

- 2.5 persons/single family detached unit
- 2.0 persons/townhouse or semi-detached unit
- 1.5 persons/apartment unit

5.5 Sanitary Sewer Construction

Sewer construction and pipe bedding shall conform to the requirements of OPSS 410 for sewer construction. A minimum 2.5 metre depth of cover shall be provided over all sanitary sewers and service laterals.

5.6 House Connections

Plan locations and invert elevations, for all house connections at the street line, shall be shown on the drawings. Minimum fall on house connections shall be 2%; maximum 8%. Where the depth of sewer is excessive, a riser may be used over the main sewers. Shop manufactured "Tee" connections shall be used for house connections to the main

sewer. Each service lateral shall be complete with a manufactured “Wye” connection and 100 mm diameter cleanout that shall extend to the ground surface level. The top of the cleanout shall be installed flush with the ground surface 300 mm outside the lot line complete with a bolted cap (Malcolm or approved equal), clearly marked “Sewer”, attached using a PVC fitting. Flexible couplings should not be used to connect the bolted cap to the cleanout. A P.V.C. gasketed cap shall be installed on each service lateral termination at the street line and made watertight. The ends of all services shall be marked by a 50 mm x 100 mm wood post extending from the service to 300 mm above the surface of the ground and the top section painted fluorescent green. Connections to Maintenance Holes shall enter the structure no higher than 0.5 m above the lowest invert, except as otherwise approved by the Municipal Engineer.

All sanitary service pipe material shall be coloured green to avoid cross connection. This includes pipe colour, wrapping, demarcation tape or stenciling.

Each property shall have it’s own individual sanitary connection.

5.7 Grinder Pumps

Should the development require the use of Grinder Pumps, they shall be E-One sewer systems curb stop c/w integral stainless steel check valve equivalent. Service box to have stainless steel stem. Isolation valves to be located at the property line of each service. Valve box covers to be stamped “SEWER”.

Service pipe to be 32 mm (minimum), Polyethylene (PE) DR-11 tubing, compression joint connections for PE service pipe requires a stainless steel tube liner with a fluted end as supplied by the corporation stop manufacturer.

Should grinder pumps be required, more detailed design, material and installation specifications will be provided by the municipality.

Grinder pumps shall remain in the ownership of the private property owner. The property owner shall be responsible for all operating, maintenance, repair and replacement costs.

5.8 Maintenance Holes

Concrete maintenance holes shall be provided at all changes in direction of the sewer and at all street intersections, but no further apart than noted:

Sewer Diameter (mm)	Maximum Spacing (m)
Up to 400	120
450 to 750	150

Maintenance Holes shall be 1200 mm dia. conforming to OPSD 701.010 or as required for larger trunk sewer sizes. Benching shall be provided in all structures.

Developer's engineer may propose alternatives in place of a standard maintenance hole, subject to approval of the Municipality. Drawings shall include manufacturer's standard and installation requirements. The structure shall include body shaft, fittings, vertical riser pipe, 600mm dia. concrete riser section(s) to set frame and cover on, cap, frame and cover and any other necessary components to complete work.

5.9 Testing and Flushing of Sewers

The complete sewer system, including house connections, shall be tested (infiltration/exfiltration/deflection), and flushed in accordance with OPSS 410, including video inspection. The Developer shall arrange the tests for sections of sewer between Maintenance Holes and shall inform the Municipal Engineer when a section is on test and ready for inspection. Sewers shall be video inspected at least twice by the developer, once immediately prior to base asphalt and once immediately prior to Final Acceptance. Any sections of sewer which fail to meet the requirements of this section shall be repaired and retested until results are satisfactory to the Municipality. All repairs and retest will be at the Developer's expense.

Testing and flushing also applied to the storm sewer pipe installed as part of the development. A sanitary sewer, storm sewer and forcemain commissioning plan will be submitted to the Operating Authority for review and comment, at least 2 weeks in advance of the proposed start date of the flushing, testing and disinfection. Notice of testing start date shall be received at least 5 days prior to the start day. Upon completion of the sanitary and storm construction, a commissioning report from the Developer's Engineer will be submitted to the Operating Authority and Municipal Engineer.

5.10 Completion and Acceptance

The complete sewage collection system installation must be approved by the Municipal Engineer prior to the issuance of building permits for the subdivision.

6.0 WATERMAINS

6.1 Approval of Plans

Plans of the entire system shall be submitted to the Municipal Engineer for approval and prepared in accordance with the Ministry of Environment, Conservation and Parks Guidelines and the Municipal Drinking Water Licensing Program (as applicable). The developer shall provide a complete MECP Form 1 – Record of Watermains (and any supporting information) for any addition to, or alteration of the municipally owned water distribution systems.

The submission shall consist of an overall plan, a plan and profile of each watermain drawn to the same scale as the roads, together with typical details of house service connections, pipe bedding and other appurtenances. Approval for construction will not be given until all the requirements of the Ministry of the Environment, Conservation and

Parks and the Municipal Drinking Water Licensing Program are fulfilled and the necessary approvals received.

6.2 Locations

- Watermain:** The watermain shall typically be installed within the road allowance, in accordance with the Municipality's Typical Cross-Section.
- Service Lines:** In general, house services shall not be installed in driveways. Where the driveway location is unknown at the time of watermain construction, service connections shall terminate at the property line at the centre of each lot.
- Main Valves:** To be located at the extension of property line, where the valve is being installed at intersections.
- Curb Stops:** To be provided for each service connection and to be located at the lot line.
- Hydrants:** Fire hydrants shall be installed at the end of cul-de-sacs and other permanent dead-end watermains. They are preferred to be located at street intersections, same side as the watermain, consistent side of road, property lines, high points, low points, and should have 2.0 metres of clearance on either side from obstructions and clear to the curb line at the front. All hydrants shall have isolation valves.
- Tracer Wire:** the tracer wire shall be looped at every valve, hydrant and fittings. The tracer wire shall be secure with the valve boxes and chamber to within 300mm of final grade with a minimum of 600mm of loose wire. Testing stations may be required.

6.3 Design

Watermains shall be designed in accordance with current MECP design guidelines. Minimum distribution pipe size shall be 150 mm diameter. Watermains shall be looped to existing municipal systems.

6.4 Material and Size

All materials for watermains, valves, valve boxes, etc. shall be supplied by the Contractor. All materials supplied under this contract shall comply with the latest edition of the applicable AWWA standard. Oils and lubricants used in assembly shall be 'Food Grade' and shall comply with the latest edition of NSF/ANSI Standard 61. **No substitutions shall be considered without the Municipality's approval.**

- Watermain:** Polyvinyl Chloride, PVC-C900 (DR18) bell and spigot with rubber gaskets. Minimum size – 150 mm. Minimum depth of cover – 1.8 m.

- Fittings:** Ductile iron, cement mortar lined, mechanical joint, AWWA C110 approved, pressure rated to 1035 kPa.
- Gate Valves:** AVK Canada Valve, Bibby, Mueller Canada Valve and/or Clow mainline valves and in mechanical joint with standard operating nut, hydrant valves to MJ to MJ gate valves with standard operating nut. All valves to be supplied with “O” ring packing for water use and open counterclockwise. Valve boxes shall be “D” slide type with No. 6 base, Bibby VB4000. Tapping valves and sleeves must meet with the approval of the local Municipality.
- Hydrants:** To conform to AWWA C502 and be Mueller Canada Valve, Century type, complete with M.J. boot, 2-64 mm hose connections and 1-100mm Storz pumper connections. Hydrants shall open counterclockwise. Colour shall be red. Hydrant length shall be such that the bottom of the upper barrel shall be 150 mm above finished grade. Operating nut shall be 31 mm.
- Services:** Min. 25 mm dia., Max. 50 mm cross-linked polyethylene (PEX) conforming to AWWA C904 and buried with 1.8m cover. PEX tubing shall include tracer wire. Main stops to be Model No. F-1000 by Ford. C.C. thread inlet/compression joint outlet. Curb stops shall be Model No. B-44-333 P.J. ball valve by Ford complete with Mueller Model No. H-726 or Concord-Daigle Model No. D-1 curb box. Service box and stem to be 1.4m to 1.8m 25mm steel upper section. Box lids shall be regular ribbed with brass pentagon plugs, clearly marked “Water”.
- Meter Pits:** For service connections greater than 30 m. in length, from the property line to the dwelling, meter pits shall be provided. Meter pits are also required for multiple residential units for typical single lots. Meter pits shall be Meuller thermal coil. Refer to Appendix D for detail.

Cathodic Protection: In accordance with OPSD 1109.011 and as noted below:

Appurtenances	Method of Protection
i) Piping	Not required.
ii) Hydrants	One anode per each (see hydrant standard drawing OPSD 1105.010).
iii) Services <ul style="list-style-type: none"> • Each copper service • Each non-metallic service 	One anode per each service. One anode installed per each curb stop and main stop.
iv) Valves	Sacrificial zinc nuts.
v) Fittings (epoxy coated) Fittings (no coating)	Sacrificial zinc nuts

Appurtenances	Method of Protection
	One anode per each or sacrificial zinc nuts.
vi) Mechanical Restraints	Sacrificial zinc nuts.

- Anode sizes shall be 5.5 kg for watermain appurtenances up to and including 300 mm diameter and 11.0 kg for watermain appurtenances greater than 300 mm.
- Anodes for steel pipe encasement shall be 11.0 kg for all sizes.
- Sacrificial zinc nuts shall be of the protecto-cap type and installed on each bolt.

Saddles: Model No. FS303 by Ford, stainless steel (18 gauge min.), double bolted. Band width to be equal to or greater than the diameter of the watermain.

Tracer Wire: All PVC watermain to be provided with a Type TWU No. 12/7 strand copper cable having thermoplastic insulation rated for underground use and strapped to the top of the pipe every 5.0 metres with a brass or galvanized clamp.

Thrust Restraints: OPSS 441.07.23 is amended to the following insert:

All thrust restraint shall be designed to adequately provide the minimum amount of pipe/joint restraint required by mechanical joint restraint device alone. Concrete thrust blocks are not an accepted method of thrust restraint in the Municipality of Kincardine except for connections to an existing main as directed by the Operating Authority or their designate.

Design of the pipe joint restraining systems shall consider the pressures that the system will be subjected to as well as any expansion and contraction due to temperature changes during and following construction of the various pipe materials selected.

Restrain lengths for watermain 100 mm to 300 mm shall be in accordance with the requirements outlined below. Restrained length calculations for watermains 400 mm and greater shall be supplied by the pipe manufacturer using the design criteria set out below.

Thrust restraint shall be provided at all fittings, bends, tees, valves, hydrants, crosses, reducers, and plugged or capped dead ends.

For DI pipe refer to AWWA C600 – Section 3.8. For PVC pipe refer to UNI-BELL and AWWA M-23.

Hydrants shall be restrained with mechanical thrust restraints.

Design Criteria (Thrust Restraint):

All inline valves up to 300 mm in size shall be mechanically restrained and as well one (1) full pipe length (6m) on each side of the restrained valve must be mechanically restrained with a minimum of two (2) steel rods to be used on the restraints.

All bends up to 200 mm in size must be mechanically restrained and as well one (1) full pipe length (6m) on each side of the restrained bend must be mechanically restrained with a minimum of two (2) steel rods to be used on the restraint.

All bends from 250 mm to 300 mm in size shall be mechanically restrained and as well two (2) full pipe lengths (12m) on each side of the restrained bend must be mechanically restrained with a minimum of four (4) steel rods to be used on the restraints.

All dead ended watermains up to 200 mm in size cap and or plug shall be mechanically restrained and three (3) full pipe lengths (18m) must be restrained prior to the end of that watermain with a minimum of two (2) steel rods to be used on the restraints.

All dead ended watermains 250 and 300 mm in size cap and or plug shall be mechanically restrained and as well five (5) full pipe lengths (30m) must be restrained prior to the end of that watermain with a minimum of four (4) steel rods to be used on the restraints.

All fitting which would include tees, fire hydrants, reducers and crosses up to 300 mm in size shall be restrained and as well two (2) full pipe length (12m) on each side of the fitting and must be mechanically restrained with a minimum of two (2) steel rods to be used on the restraints.

All branch valves shall be treated as dead end watermains and shall be restrained according to the above mentioned dead end watermain criteria.

NOTE: If any joint is encountered in the above restrained lengths it must also be restrained.

6.5 Watermain Construction

All watermain and appurtenances are to be installed, bedded and backfilled in accordance with current Ontario Provincial Standard Specifications, Safe Drinking Water Act, Drinking Water Works Permit, The Municipal Drinking Water License, and the most current recent version of ANSI/AWWA C651, the MECP "Watermain Disinfection Procedure", and to the satisfaction of the Municipality. Minimum 1.8 metre depth of cover over all mains and services. Main valves and hydrant sets shall, generally, be located at a maximum spacing of 200 metres and 150 metres, respectively. Hydrant spacing for commercial areas may require reduced spacing. At

main intersections, a main valve shall be provided at each direction from the intersection. All dead end watermains shall be provided with at 50 mm. blow off assembly.

6.6 Flushing, Testing and Disinfection

All watermain shall be tested, flushed, swabbed and disinfected. Such procedures shall be in accordance with OPSS 441 for pressure testing and the most recent version of AWWA C651 and the MECP "Watermain Disinfection Procedure" for disinfection and connection to the waterworks system. The Developer shall inform the Municipal Engineer when the watermain is to be tested and disinfected, with at least 48 hours notice.

All costs incurred by the Municipality with regards to watermain flushing, testing and disinfection shall be charged back to the Developer.

The pressure testing shall be in accordance with OPSS 441.07.24 Hydrostatic Testing and under the supervision of the Municipal Operating Authority.

All hydrant leads, services, stubs, blow-offs etc. shall be subject to the hydrostatic pressure testing. Hydrant valves shall be in the open position to subject the hydrant to the test as well.

Bacteriological testing will be completed by the municipal operating authority. The Developer will be billed for any testing or retesting required. Any failure of the testing and disinfecting shall require the Developer to re-flush, retest and/or re-disinfect the watermain until the watermain has met the requirements of the Ontario Provincial Standard Specifications and the MECP, to the satisfaction of the Municipality. Minimum requirements for bacteriological testing are:

- Escherichia coli – not detectable
- Total coliforms – not detectable

All chemicals and materials used in the disinfecting of the drinking water system shall conform to the following standards:

- AWWA B300 for Hypochlorites
- AWWA B301 for Liquid Chlorine
- NSF/ANSI 60, Drinking Water Treatment Chemicals – Health Effects
- NSF/ANSI 61, Drinking Water System Components – Health Effects.

After the final connection to the existing main, the Developer's contractor will test the integrity of the new underground tracer wire by applying a conductivity signal and confirming the signal correlation on all watermains and services. This testing shall be completed by an independent third-party. The Operating Authority will complete the same process after paving to ensure no damage has occurred. Should the Operating Authority discover any issues, they will inform the Developer's Engineer and all repairs will be made at the Developer's expense.

A watermain commissioning plan will be submitted to the Operating Authority for review and comment, a minimum of two (2) weeks in advance of the proposed start date of the flushing, testing and disinfection. The commissioning plan to include details on the planned de-chlorination process and third-party testing for tracer wire connectivity. Upon completion of the watermain construction, a watermain commissioning report from the Developer's Engineer will be submitted to the Operating Authority and Municipal Engineer.

6.7 Completion and Acceptance

The complete water distribution system installation must be approved by the Municipality prior to the issuance of building permits for the subdivision.

7.0 UTILITIES AND STREET LIGHTING

7.1 Telecommunications

Telecommunication services, which include telephone, internet, and television, shall be provided and installed in a joint utility trench in the corridor at the location provided in the typical cross section. The Developer must bear the cost of any surcharges for underground installation made by the provider(s) and must grant them any easements for their services.

7.2 Telecommunication Companies

There are a number of telecommunication companies that may have interest in providing installations. The developer shall insure that all have the opportunity to be installed and shall provide service. The developer shall provide to the Municipality documentation, satisfactory to the municipality that all such companies have been contacted and offered the opportunity for installation.

7.3 Electrical

Underground electrical installation shall be completed to the satisfaction of the local power distribution company based on their most current specification.

7.4 Gas Servicing

Developers shall insure that a corridor is provided for the future installation of gas distribution mains and services throughout the subdivision. Should, within the time that the development is being serviced, gas supply is available, then the developer shall arrange for its installation.

7.5 Street Lighting

Street lighting in residential subdivisions shall meet as a minimum the RP8 lighting standards.

Street light shall be Lumec, RPS series fixtures, complete with aluminum arms and concrete poles. Poles shall be StressCrete round tapered poles, E300-BPR-GMOO S/F 120

Where decorative poles and lights are to be used, decorative lights shall be Lumec, Ancestra (AT40) series. Poles shall be USI Grandview series.

8.0 LOT GRADING

As part of a submission with the servicing drawings, an overall lot grading plan shall be provided to the Municipality. Existing ground elevation contours shall be shown with not greater than 1 m intervals and spot elevations shall be located along lot lines adjacent to the development. Further, spot elevations shall be shown a minimum of 30 m beyond the limit of the development to provide an indication of the adjacent grading.

Section B of Appendix “C” should be referred to for specific standards related to lot grading, however, the general requirements are as follows:

The lot grading plan to be provided shall include proposed finish grade elevations and details as follows:

- All lot corners.
- All changes in grades.
- Along the centreline of the road at 20 m intervals.
- On all building sites, elevations adjacent to foundations, retaining walls or changes in elevation.
- Ditch or swale bottoms.
- All intersecting lot lines.
- Any location where the grade changes in slope.

Lot grading drawings shall include directions of both minor and major overland flow routes with arrows on drawings.

These drawings shall be provided together with stormwater management reports and stormwater management facility drawings to provide information suitable for the Building Official to review individual site specific grading plans.

Any regional flood, fill lines or erosion control lines shall be shown on the lot grading plans to the satisfaction of the Conservation Authority.

The Developer shall note that the review and approval of a lot grading plan by the Municipality does not provide assurance that a specific style of house will suit an individual lot and applications for building permits must provide for a dwelling unit that suits the style of grading proposed by the Developer.

General lot grading standards are as follows:

- Lot grading is 2% minimum, 6% maximum.
- Driveways – 2% minimum, 6% maximum.
- Drainage Swale – 2% minimum, invert slope – 0.3 m minimum depth, 4:1 maximum side slopes.
- Terraces or Changes of Grades shall be at a slope no more than 3:1. Where there are terraces or retaining walls proposed, a horizontal area a minimum of 2 m in width, shall be provided at the extent of each change in grade before terrace slopes are proposed.

9.0 PARKLAND AND LANDSCAPING

9.1 Parkland

Where park areas are dedicated to the Municipality as part of the development, the Developer shall grade and seed the parklands so that they are suitable for recreational use. Grading shall be to a minimum slope of 2% and appropriate drainage swales and outlets shall be provided to the municipal sewer system or to an appropriate outlet. The requirement for fencing or further landscaping of a park area will be reviewed with the Developer at the time of Draft Plan submission along with the location and geometry of a proposed park. Stormwater management facilities and environmentally sensitive areas are not to be considered appropriate for parkland dedication.

9.2 Landscaping

Boulevards shall be finished with a minimum of 150 mm of topsail and shall be sodded or seeded.

At least one tree shall be planted in the boulevard in front of each lot (single family or semi-detached) generally within one year of the completion of the curb and gutter and paving in that section of subdivision. On corner lots, a second tree will be required on the flankage. Trees are to be planted so as not to interfere with other street functions or services when the tree matures. Trees shall be planted in the boulevard, generally opposite the driveway on any lot and not interfering with municipal services.

Trees shall a minimum 60-70 mm dia. measured 300 mm above the ground and shall be No. 1 nursery stock. The municipality maintains a list of current species of trees acceptable for use in new development and the Director of Public Works shall be consulted to designate species at the time of planting.

Tree planting and care procedure shall include the following:

- Provide a tree planting plan. Species may be selected from a species list that is available at the municipality.
- Check for underground services of: hydro, water, phone and cable by obtaining locates.

- Dig holes with appropriate equipment. Holes shall be 250 mm wider in circumference and the same depth as the root ball.
- Loosen, untie and fold down burlap and rope from tree trunk and place in hole. Place root ball in the centre of hole and ensure that the top of the root ball is flush with surrounding terrain.
- Backfill with native soil. Adjust if necessary and pack the root ball firmly.
- Add a Mulch ring at a depth of 10 cm (4") at the base of the tree keeping the Mulch from touching the trunk directly. Termite resistant mulch shall be used in the Termite Zone.
- Stake tree for two years using rubber garden hose to protect tree from being cut by support wires.
- To protect the trunk from line trimmers where mulch is not used - use a 20 cm (8") section of solid drainage tile.
- Water newly-planted trees regularly during the first year.
- Remove stakes from trees after 2 years or if tree is in a windy location postpone stake removal for 2 more years adjusting the wire and hose accordingly.
- Top up mulch ring as required on yearly basis.
- Use care when grass cutting or when using a line trimmer at the base of the tree ensuring the trunk is not struck.

All trees that die or fail to grow (as per the discretion of the Municipality) prior to "Final Acceptance" shall be replaced by the Developer.

9.3 Walkways & Beach Access

Walkways shown on the Plan of Subdivision shall be constructed between parkland and adjacent streets or from street to street. They shall consist of a concrete sidewalk of minimum width of 1.5 m. The walkway boulevard shall be landscaped, topsoiled and seeded. A standard black 1.5 m high chain link fence shall be placed along both sides of the walkway right-of-way with bollards placed at each end of prevent vehicular traffic from using the walkway.

When the development is adjacent to the Lake Huron shoreline, the developer shall provide for at least one public beach access. The public beach access shall be engineered and include stairs.

9.4 Trails

The Municipality supports and promotes walkability and multiple transportation opportunities within the community. Multi-Use trails shown on the Plan of Subdivision shall be constructed between parkland and adjacent streets, from street to street or from street to existing trail networks. They shall consist of a 50 mm HL-3 hot mix trail of minimum width of 3.0 m, with a Granular "A" base depth a minimum of 150 mm.

10.0 TRAFFIC AND STREET SIGNS

The Developer shall be responsible for erecting all traffic street name signs within the development. These signs may be provided by the Municipality at the Developer's expense. The Developer shall further be responsible for providing lot identification signs on each lot outlining the appropriate municipal address (911 address) for said lot.

11.0 ASSET MANAGEMENT

Prior to Final Acceptance of the services as defined in the Subdivision or Development agreement, the developer shall engage their Engineer to provide to the Municipality a detailed list of the cost of all of the assets for the purpose of the Municipality's asset management system.

12.0 PAYMENT TO DEVELOPERS

The Municipality shall not be liable for any costs arising out of the construction of services except the oversizing of the works are required for future development.

The Municipality will pay the marginal cost of any requested oversizing of sanitary collection, water distribution, stormwater collection works and appurtenances beyond an increase in one nominal pipe size above that which might be needed for the development.

For example, where a sanitary sewer (or a watermain) designed solely for the development might require the developer to install a 250 mm dia. pipe, a request for oversizing beyond one pipe size or 300 mm would result in the Municipality paying the marginal cost.

Where a storm sewer is requested that is larger than that required for the development and any offsite flows (based on their current developed state), the Municipality will pay the marginal difference in cost for supplying the larger size pipe and appurtenances beyond one incremental pipe size of that needed.

13.0 REVISIONS TO SERVICING GUIDELINES

The Municipality reserves the right to amend these guidelines at any time and/or to further clarify the requirements found herein.

APPENDIX “A”

**TYPICAL CROSS SECTION FOR NEW, URBAN RESIDENTIAL
DEVELOPMENT**

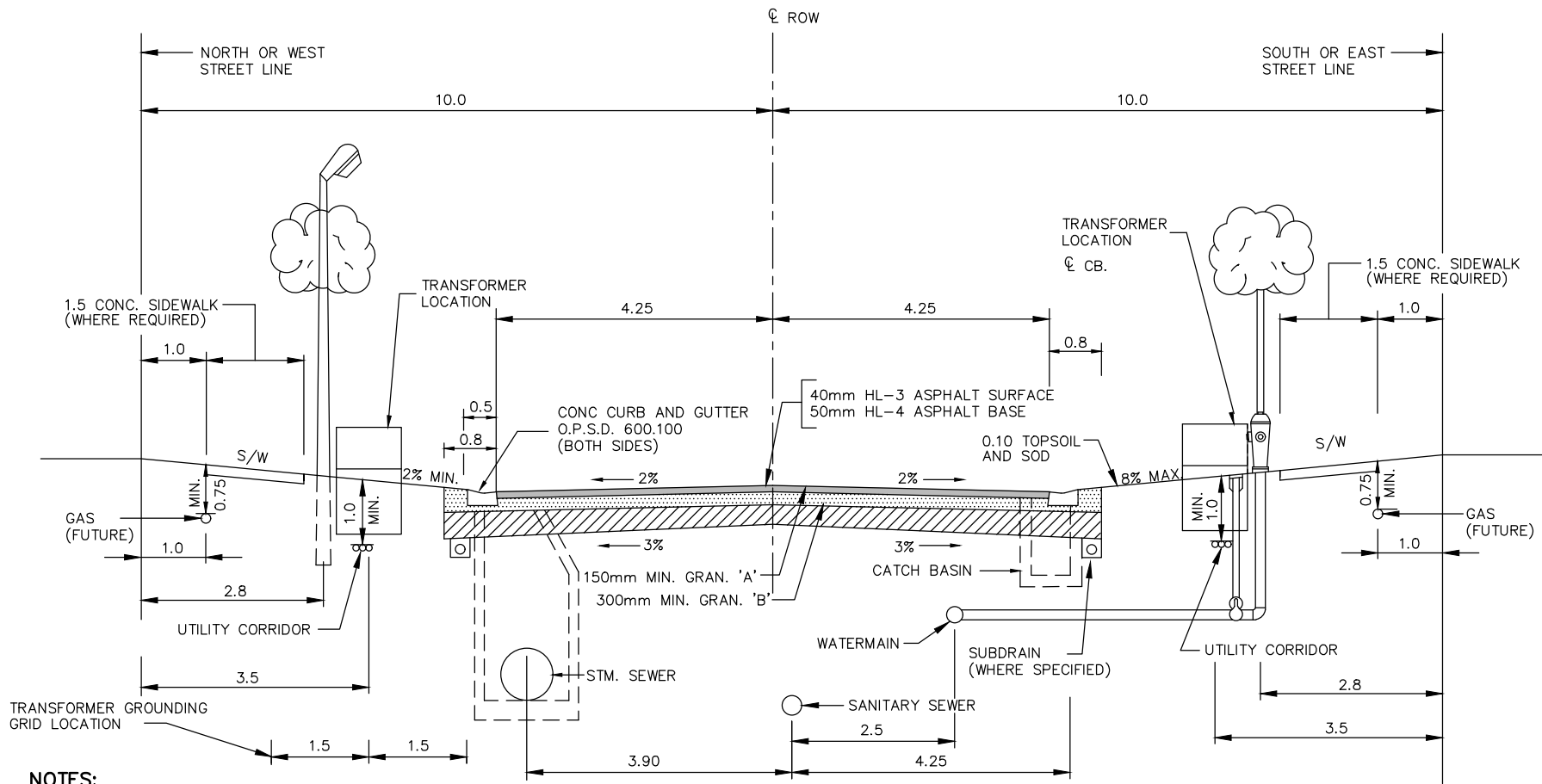

NOTES:

1. TOPSOIL TO BE REMOVED TO ITS FULL DEPTH ALONG ENTIRE WIDTH OF ROAD BETWEEN CURBS.
2. BOULEVARD TO BE FULLY SODDED AS SPECIFIED.
3. ROAD CROSSINGS DEPTHS FOR UTILITIES – HYDRO 1.2 MIN.
– TELECOMMUNICATIONS, NATURAL GAS TV 1.0 MIN.
– WATER 1.8 MIN.
4. ALL WATER SERVICE BOXES TO BE SET AT PROPERTY LINE.
5. ROAD CONSTRUCTION DESIGN TO BE CONFIRMED BY GEOTECHNICAL ENGINEER
6. SIDEWALK SHALL BE PROVIDED IF REQUIRED BY MUNICIPALITY.
7. IF SIDEWALK IS PROVIDED, TRANSFORMER IS TO BE ON OPPOSITE SIDE TO SIDEWALK WHERE POSSIBLE.



**Municipality of
Kincardine**

**Typical 20 meter Urban Subdivision
Cross Section and Service Locations
Local Residential Streets**

DATE OF REVISION - Oct. 17, 2022



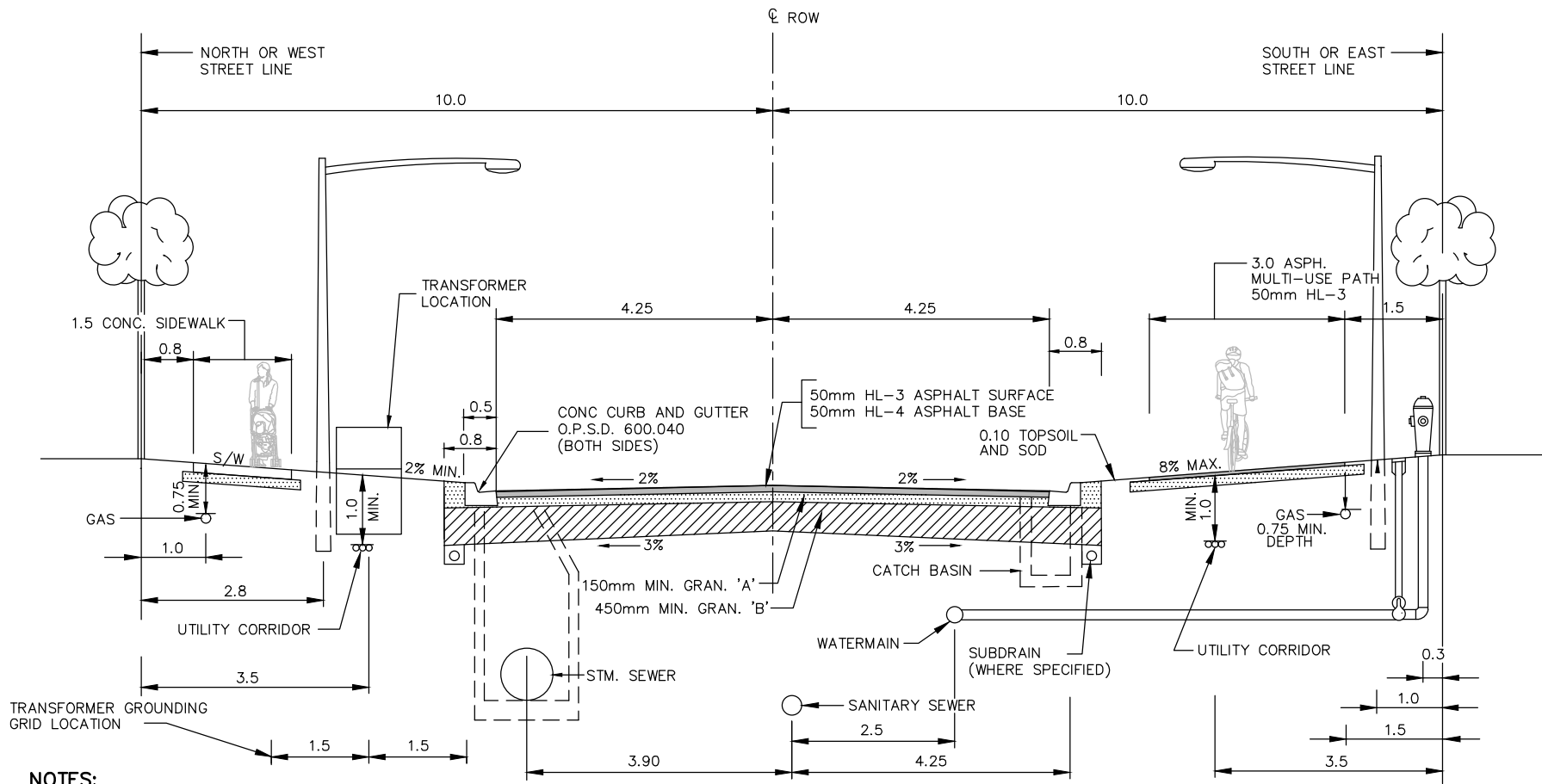

NOTES:

1. TOPSOIL TO REMOVED TO ITS FULL DEPTH ALONG ENTIRE WIDTH OF ROAD BETWEEN CURBS.
2. BOULEVARD TO BE FULLY SODDED AS SPECIFIED.
3. ROAD CROSSINGS DEPTHS FOR UTILITIES – HYDRO 1.2 MIN.
– TELECOMMUNICATIONS, NATURAL GAS TV 1.0 MIN.
– WATER 1.8 MIN.
4. ALL WATER SERVICE BOXES TO BE SET AT PROPERTY LINE.
5. ROAD CONSTRUCTION DESIGN TO BE CONFIRMED BY GEOTECHNICAL ENGINEER
6. SIDEWALK AND MULTI-USE PATH SHALL BE PROVIDED AS SHOWN.
7. STREET LIGHTS SHALL BE ON BOTH SIDES OF THE ROAD, AND SUBJECT TO RP8 LIGHTING STANDARDS AND BOOK 18 – CYCLING FACILITIES GUIDANCE.



**Municipality of
Kincardine**

**Typical 20 meter Urban Subdivision
Cross Section and Service Locations
Local Collector/School Streets**

DATE OF REVISION - April 19, 2024



APPENDIX “B”

TYPICAL CROSS SECTION FOR VARIOUS TYPES OF DEVELOPMENT

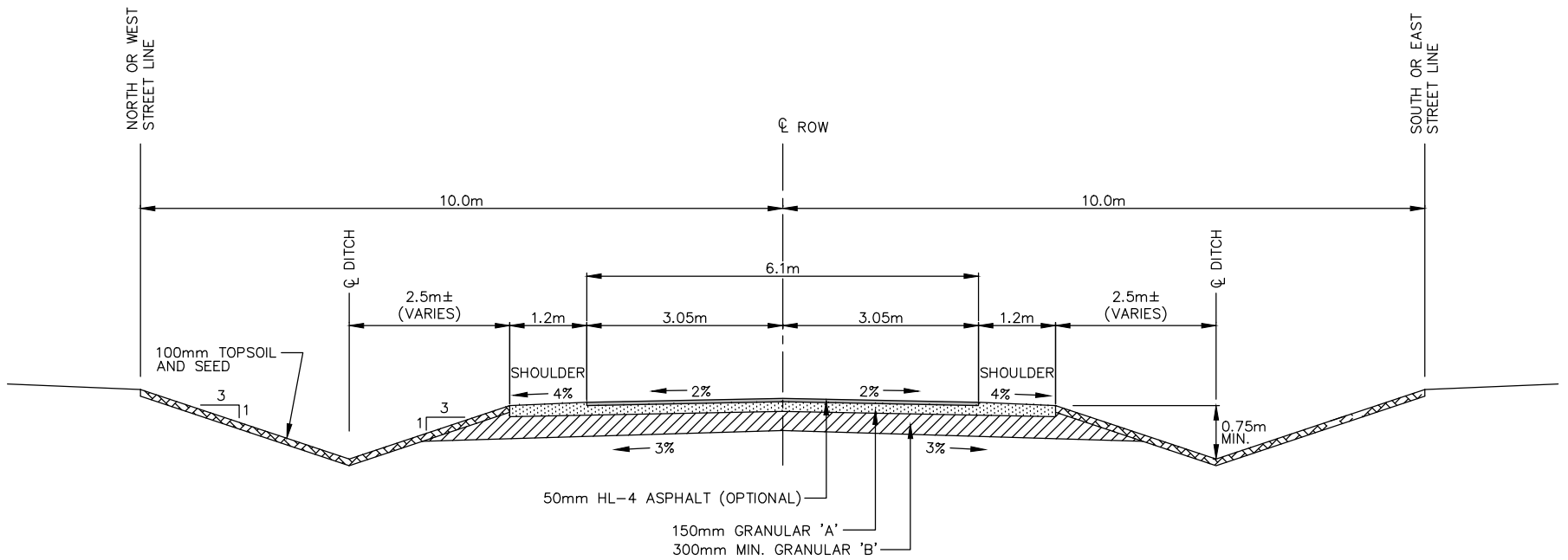

NOTES:

1. TOPSOIL TO REMOVED TO ITS FULL DEPTH ALONG ENTIRE WIDTH OF ROAD BETWEEN TOPS OF DITCH BACKSLOPES
2. BOULEVARD TO BE FULLY SEEDDED AS SPECIFIED.
3. ROAD CONSTRUCTION DESIGN TO BE CONFIRMED BY GEOTECHNICAL ENGINEER.



Municipality of Kincardine
Typical Rural Road Cross Section
Local Cottage Residential Streets

DATE OF REVISION - Apr. 12, 2017

DRAFT



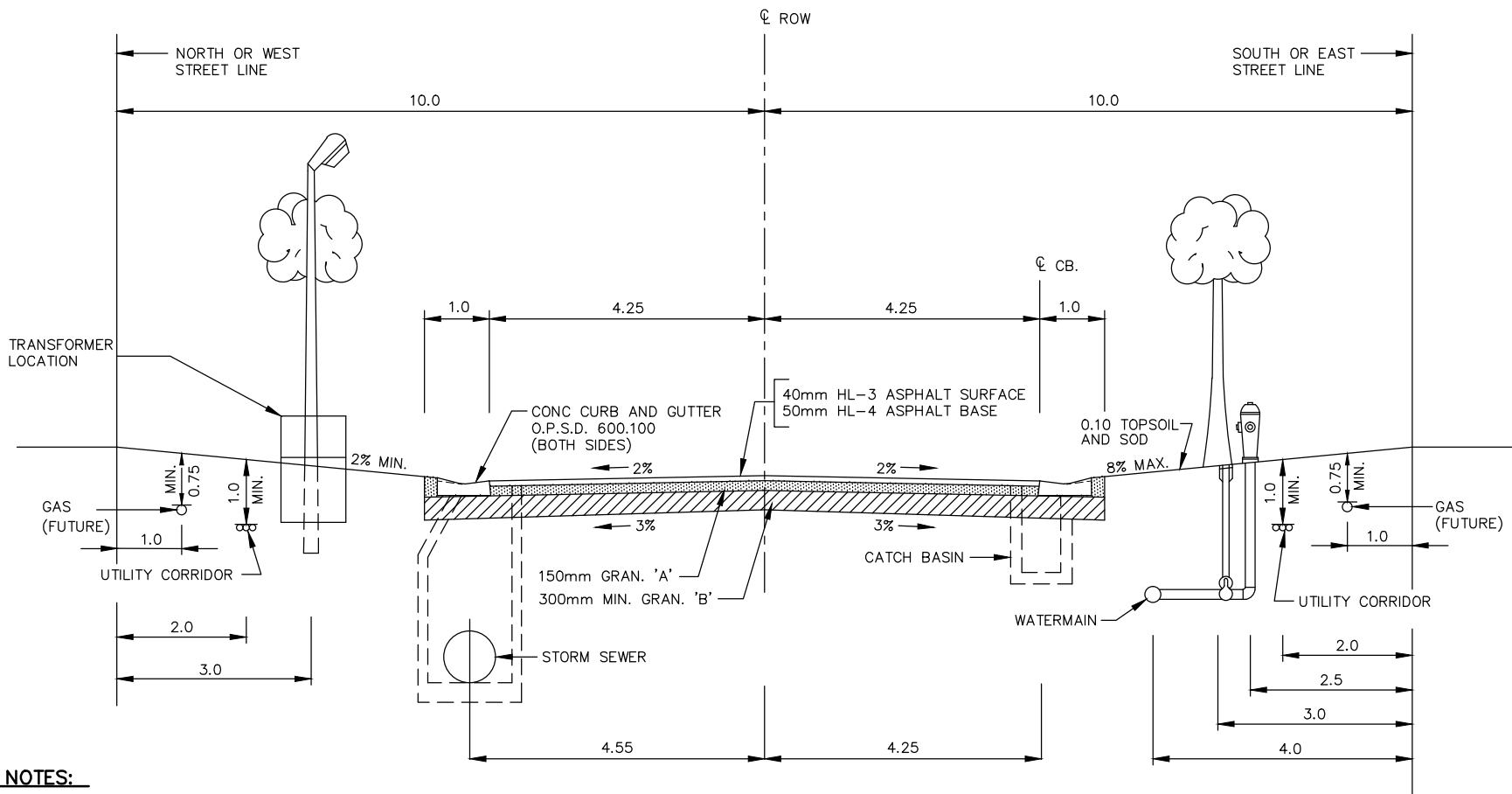

NOTES:

1. TOPSOIL TO REMOVED TO ITS FULL DEPTH ALONG ENTIRE WIDTH OF ROAD BETWEEN CURBS.
2. BOULEVARD TO BE FULLY SODDED AS SPECIFIED.
3. ROAD CROSSINGS DEPTHS FOR UTILITIES – HYDRO 1.2 MIN.
 – BELL TELEPHONE, UNION GAS, CABLE TV 1.0 MIN.
 – WATER 1.8 MIN.
4. ALL WATER SERVICE BOXES TO BE SET AT PROPERTY LINE.
5. ROAD CONSTRUCTION DESIGN TO BE CONFIRMED BY GEOTECHNICAL ENGINEER.



**Municipality of
Kincardine**

**Typical 20 meter Suburban Subdivision
Section and Service Locations
Local Residential Streets**

DATE OF REVISION - Apr 12, 2017

DRAFT



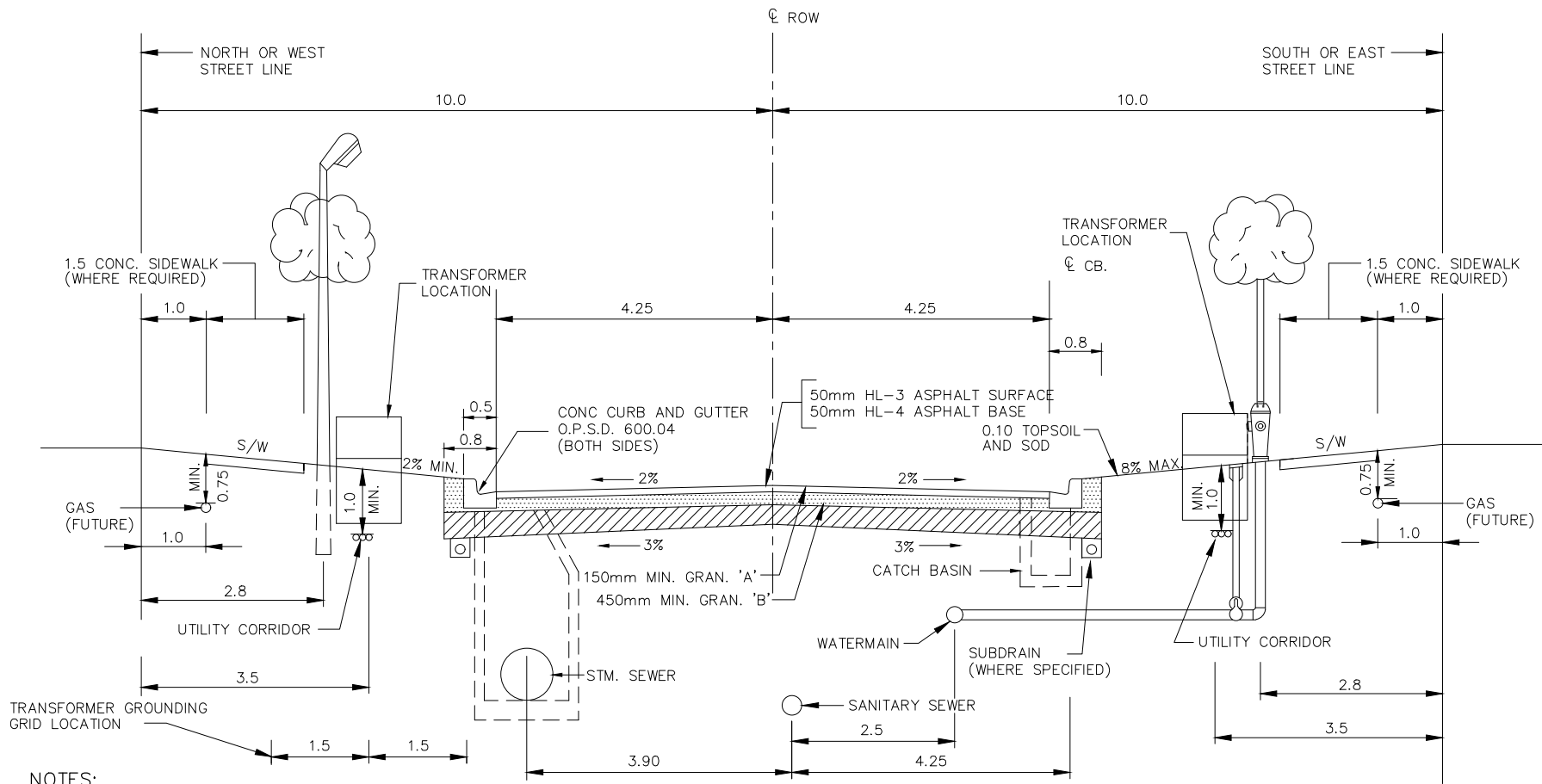

NOTES:

1. TOPSOIL TO BE REMOVED TO ITS FULL DEPTH ALONG ENTIRE WIDTH OF ROAD BETWEEN CURBS.
2. BOULEVARD TO BE FULLY SODDED AS SPECIFIED.
3. ROAD CROSSINGS DEPTHS FOR UTILITIES – HYDRO 1.2 MIN.
– TELECOMMUNICATIONS, NATURAL GAS 1.0 MIN.
– WATER 1.8 MIN.
4. ALL WATER SERVICE BOXES TO BE SET AT PROPERTY LINE.
5. ROAD CONSTRUCTION DESIGN TO BE CONFIRMED BY GEOTECHNICAL ENGINEER
6. SIDEWALK SHALL BE PROVIDED IF REQUIRED BY MUNICIPALITY.
7. IF SIDEWALK IS PROVIDED, TRANSFORMER IS TO BE ON OPPOSITE SIDE TO SIDEWALK WHERE POSSIBLE.



Municipality of Kincardine

Typical 20 meter Urban Industrial Section and Service Locations Local Industrial Streets

DATE OF REVISION - Oct. 17, 2022



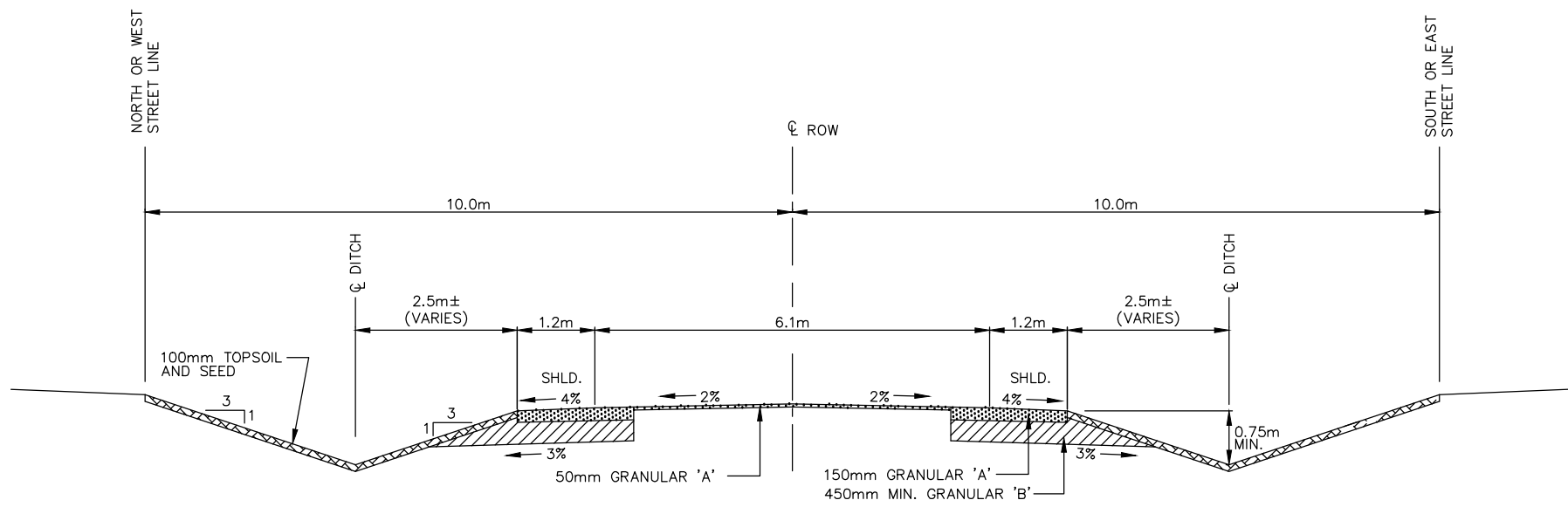

NOTES:

1. TOPSOIL TO BE REMOVED TO ITS FULL DEPTH ALONG ENTIRE WIDTH OF ROAD BETWEEN TOPS OF DITCH BACKSLOPES
2. BOULEVARD TO BE FULLY SEEDED AS SPECIFIED.
3. ROAD CONSTRUCTION DESIGN TO BE CONFIRMED BY GEOTECHNICAL ENGINEER
4. EDGE CUT ALONG BOTH SIDES OF RURAL ROAD.



**Municipality of
Kincardine**

**Typical Rural Agricultural Road
Widening Cross Section**

DATE OF REVISION - Apr. 12, 2017

DRAFT



APPENDIX “C”

STORMWATER MANAGEMENT GUIDELINES FOR SITE PLANS OR SMALL DEVELOPMENTS

SECTION A – STORM DRAINAGE AND STORMWATER MANAGEMENT

1.0 DRAINAGE POLICIES

1.1 Application

These drainage policies will apply to all development or redevelopment requiring site plans or other planning approvals. Where the local Conservation Authority determines the development is in their regulated area or they have an interest in the development, their guidelines and policies shall apply.

1.2 Drainage Objectives

The Municipality of Kincardine has set the following objectives for the management of storm drainage within its boundaries:

- Reduce to acceptable levels, the potential risk of health hazards, loss of life and property damage from flooding.
- Reduce to acceptable levels, the incidence of inconvenience caused by surface ponding and flooding.
- Ensure that any development or redevelopment minimizes the impact of change to the groundwater regime; increased pollution; increased erosion or increased sediment transport, especially during construction; and impact to surrounding lands and areas of existing development.
- Maintain, where applicable, any natural stream channel geometry insofar as it is feasible while achieving the above objectives.

2.0 ATTAINMENT OF DRAINAGE OBJECTIVES

2.1 Major and Minor Systems

In general, the Municipality of Kincardine supports the concept of drainage having two separate and distinct components – the minor drainage system and the major drainage system. The minor system comprises swales, street gutters, ditches, catch basins and storm sewers. The major system comprises the natural streams and valleys and man-made channels, roads, or other overland conveyance systems.

2.2 Run-off Quality Control

The Municipality requires developers, contractors and builders to plan and execute their operations so as to minimize sediment and debris pickup and transport to water bodies. The degree of control and methods used must meet the regulations and guidelines of the MECP, MNRF, MTO, and local conservation authorities. The Municipality will expect all erosion control works to be properly maintained throughout the duration of the project.

2.3 Run-off Quantity Control

Quantity control shall be restricted to post-development flows between the 2 and 100 year/ Regional storm events.

2.4 Master Drainage Plans

The Municipality requires a Master Drainage Plan for all proposed urban developments. The primary purpose of the Master Drainage Plan is to define the effects of urban development and to determine the solution that is compatible with the objectives for the watershed.

2.5 Conservation Authority Criteria

In the design of new drainage systems within areas regulated by the local Conservation Authority, the Developer's Engineer will be required to follow the most recent edition of the Authority's Stormwater Management Policies and Technical Guidelines.

3.0 MAJOR SYSTEM

3.1 Hazard Lands and Floodlines

The Municipality of Kincardine requires that Hazard Lands be clearly defined on all watersheds and that no development other than necessary access or services be located herein. The Municipality also requires that the floodplains that would result from the 1:100 and Regional storms be defined for predevelopment and post development conditions. Consultation with the local Conservation Authority will be necessary when dealing with Hazard Lands.

3.2 Detention Ponds

Detention Ponds shall be design so as to minimize any adverse effects to the environment as well as ensuring the safety of local residents. Unless noted otherwise, detention ponds are to be designed in accordance with the Ministry of the Environment, Conservation and Parks Stormwater Management Planning and Design Manual (March 2003), or the latest edition.

4.0 MINOR SYSTEM

4.1 Watershed Area

The watershed area shall be determined from the contour plans and shall include all areas that naturally drain into the system. Fringe areas not accommodated in adjacent drainage systems, and any areas which may become tributary by reason of regrading.

4.2 Storm Drainage Plans

External Areas

A plan shall be prepared to a scale dependent on the size of the watershed area, to show the nature of the drainage of the lands surrounding the development site. The area to be developed and all existing contours used to justify the design shall be clearly shown. This plan shall be prepared and submitted to the Municipality's Engineer at the functional report stage.

Internal Drainage Plan

All internal drainage plans shall be prepared and shall include all streets, blocks, lots and easements. The proposed storm sewer system shall be shown on this plan with all maintenance holes and the area contributing to each structure shall be clearly outlined on the plan. The area in hectares and the run-off coefficient shall be shown within the contributing area.

In determining the contributing area to each storm sewer structure, the proposed lot grading must be considered to maintain consistency in the design.

The length, size, and grade of each section of the minor system shall also be shown on the storm drainage plan. Arrows should depict the overland flow route and the extent of flooding from the major storm.

Rain water leaders shall not be connected directly to the storm sewer system. Leaders on all single family and semi-detached residential units shall be constructed in a manner so as to not interfere with adjacent properties. Sump pump discharge should discharge to the side yard swale.

5.0 HYDRAULIC DESIGN

5.1 Design Levels

The system of street gutters, catch basins, storm sewers or open ditches, where permitted, shall be designed for the 1:5 year storm. Culverts or sewers crossing major County roads or Provincial highways shall be designed and approved in accordance with the requirements of the Bruce County Highways Department or the Ministry of Transportation, respectively.

5.2 Rational Method

In general, the Rational Method shall be used for the sizing of the minor sewer system at the final design stage. Calculations based on a hydrologic simulation model are required for systems serving large areas or involving treatment and/or storage systems.

5.3 Stormwater Management Report

Hydrologic studies should describe the model parameters and criteria for their selection as well as input and output data. The Consulting Engineer has the responsibility for the computations, and the Municipality's Engineer shall check the main assumptions and the input data. All information required for this verification shall be submitted with the hydrologic computations. Copies of the report, where required, shall be provided to the local Conservation Authority and MECP for approval purposes.

Each report shall include a section outlining the following:

- Run-off Quantity Control
 - Address the impact of the minor and major storm as required in these guidelines for both pre development and post development regimes.
- Run-off Quality Control
 - Address best management practices proposed to achieve desired treatment.
 - Make reference to MECP Stormwater Management Planning and Design manual and Design Criteria for Sanitary Sewers, Storm Sewers and Forcemains.
- Erosion and Sediment Control Plan
 - Provide comments and detail on a Site Plan or a separate plan as part of the submission.
- Major System/Overland Flow Routes
 - Provide extent of flood for the Major Storm or Site Plan
 - Show major storm route
 - Comment on a right to access of major storm routes based on land ownership on adjacent lands
- Maintenance Considerations
 - Address ownership and obligation for maintenance
 - A maintenance manual outlining maintenance tasks and frequency of maintenance activities shall be provided as part of the Stormwater Management Report process.
- Facility Access
 - Access to all areas of any proposed facility needs to be detailed and commented on in the report.

6.0 STORM SEWER DESIGN

The requirements for storm sewer design shall be in accordance with the latest edition of the Ministry of the Environment Design Guidelines, as summarized below.

6.1 Rainfall Intensity Data

Rainfall intensity data to be used in storm sewer design shall be the most current data provided by Environment Canada for the Goderich area.

6.2 Design Storm Events

a) Rational Method

Stormwater run-off rates to be computed using the Goderich area I.D.F. curve information.

b) Hydrologic Simulation Models

Stormwater run-off rates to be computed using the Chicago distribution for the 6 hour storm unless otherwise required by external review agencies (Conservation Authority or MTO, etc.).

6.3 Run-off or Imperviousness Coefficients

Run-off coefficients to be used in storm sewer design with the Rational Method shall be based upon soil types, slope, and initial moisture conditions within the following ranges:

Asphalt, concrete, roof areas	0.90 – 1.00
Grassed areas, parkland, agricultural	0.15 – 0.35
Brick Road	0.70 – 0.85
Sandy Soil	0.05 - 0.25
Playgrounds	0.20 – 0.35
Gravel	0.60 – 0.70
Forest and dense wooded areas	0.10 – 0.25
Permeable pavements	0.15 – 0.25
Commercial	0.75 – 0.85
Industrial	0.65 – 0.75
Residential:	
– Single Family	0.40 – 0.45
– Semi-detached	0.45 – 0.60
– Row housing, Town housing	0.50 – 0.70
– Apartments	0.60 – 0.75
– Institutional	0.40 – 0.75

A ten minute entry time at the head of the system must be utilized unless large external drainage areas exist. (In this case, separate time of concentration calculations should be provided).

6.4 Pipe Capacities

Manning's Formula shall be used in determining the capacity of all storm sewers. The capacity of the sewer shall be determined on the basis of the pipe flowing full.

The value of the roughness coefficient 'n' used in the Manning's Formula shall be as follows:

- | | |
|-------------------------------------|-------|
| (a) Concrete/Plastic pipe all sizes | 0.013 |
|-------------------------------------|-------|

In cases where the storm sewer crosses a recent utility trench at an elevation higher than the elevation of the utility, a support system shall be designed to prevent settlements of the storm sewer, or alternatively the utility trench is to be excavated and backfilled with compacted crushed stone or concrete to adequately support the storm sewer. When the storm sewer passes under an existing utility, adequate support shall construction to prevent damage to that utility. In either case, the support system shall meet the minimum requirements provided by the utility company.

6.13 Changes in Pipe Size

No decrease of pipe size from a larger upstream pipe to a smaller downstream size will be allowed regardless of the increase in grade.

6.14 Sewer Pipe Materials

- a) Concrete Sewer Pipe (Rigid)
 - 150 mm to 375 mm Class 3
 - 375 mm or greater as specified in the tender form
- b) Polyvinyl Chloride (PVC) Pipe (Flexible)
 - Class SDR35 or Class V (320 kPa)
 - Annular ribbed profile for ribbed pipe
- c) Polyethylene Sewer Pipe (Flexible) – CSA certified Sewer Class to B 182.6
 - 150 mm to 600 mm
 - Smooth inner wall, annular corrugated profile (320 kPa), 15 PSI bell and spigot joints shall have elastomeric gaskets (CSA certified to B 182.6)

The Municipality shall be consulted for the material of any storm sewer > 900 mm or deeper than 5 metres.

6.15 Pipe Bedding

The class of pipe and the type of bedding shall be selected to suit loading and proposed construction conditions. Details and types of bedding are illustrated in OPS Drawing 802.03.

6.16 Backfill for Sewers

Backfill for sewers shall be in accordance with OPSD 803.04.

6.17 Private Drain Connections

Private storm sewer service connections will be provided for all new development. Sump pumps shall discharge to these private drain connections. Schedule 'B' provides a foundation drain connection detail for new development.

7.0 MAINTENANCE HOLES

7.1 Location

Maintenance Holes shall be located at each change in alignment, grade or pipe material, at all pipe junctions and at intervals along the pipe to permit entry for maintenance to the sewer.

7.2 Maximum Spacing of Maintenance Holes

Maintenance Hole spacing shall be as per MECP Design Guidelines as follows:

Sewer Diameter (mm)	Maximum Spacing (m)
250 to 975	110
1050 to 1350	130
1500 to 1650	160
1800 and above	305

7.3 Maintenance Hole Types

Maintenance holes may be constructed of precast or poured concrete. The standard maintenance hole details as shown on the OPS Drawings shall be used for maintenance holes. In cases where the standard drawings are not applicable, the maintenance holes shall be individually designed and detailed.

Precast maintenance holes shall conform to ASTM specifications C-478 M latest revision.

A reference shall be made on all profile drawings to the type and size of all storm maintenance holes.

7.4 Maintenance Hole Design

- a) Safety gratings shall be provided in all maintenance holes when the depth of the structure exceeds 5.0 m.
- b) When the difference in elevation between the obvert of the inlet and outlet pipes exceeds 0.9 m, a drop structure shall be placed on the inlet pipe.
- c) All storm sewer maintenance holes shall be benched in accordance with the OPS Drawings.

7.5 Grades for Maintenance Hole Frames and Covers

All maintenance holes located within the traveled portion of a roadway shall have the rim elevation set flush to the base course of asphalt. Prior to the placement of the surface course asphalt the maintenance hole frame shall be adjusted to the finished grade of asphalt. The concreting and setting of the frame and cover shall be in

accordance with the details on the OPS Drawings. A maximum of 300 mm of modular rings shall be permitted on maintenance hole in new subdivisions.

7.6 Head Losses Through Maintenance Holes

Suitable drops shall be provided across all maintenance holes to compensate for the loss of energy due to the change in flow velocity and for the difference in the depth of flow in the sewers;

The minimum drops across maintenance holes shall be as follows:

Change of Direction	Minimum Drop (mm)
1 to 45 degrees	30 mm
46 to 90 degrees	60 mm

8.0 CATCH BASINS

8.1 Location and Spacing

Catch basins shall be generally located upstream of sidewalk crossings at intersections.

Catch basins spacing will vary with street width, grade and cross fall, the location shall be provided on both sides of the street at all low areas with the maximum spacing as noted:

Road Gradient (%)	Maximum Spacing (m)
0 to 3	110
3.1 to 4.5	90
Over 4.5	75

Double catch basins shall normally be required when the catch basin intercepts flow from more than one direction. Single catch basins may be used in the case where the total length of drainage to the catch basin does not exceed 95 metres, subject to the analysis of the major – minor system.

Rear lot catch basins and connections shall be located as outlined in the lot grading criteria and in all cases shall discharge/connect to a structure.

8.2 Catch Basin Types

Catch basins must be of the precast type with full depth sumps, as shown on the OPS Drawing 705.010.

Special catch basins and inlet structures shall be fully designed and detailed by the Consulting Engineer.

During the design phase, discussion and consideration shall be given to the recommendations contained within the Kincardine Master Cycling Plan.

8.3 Catch Basin Connections

Type	Minimum Size of Connection	Minimum Grade of Connection
Single and Double Catch Basins	300 mm	1.0%
Rear Lot Catch Basin	250 mm	1.0%

8.4 Catch Basins Frame and Covers

The frame and cover for catch basins shall be as detailed in the OPS Drawing 400.110.

9.0 INLETS, OUTFALLS AND SPECIAL STRUCTURES

9.1 Inlets

Inlet structures must be fully designed and detailed on the Engineering Drawings.

Gabions, rip rap or concrete shall be provided at all inlets to protect against erosion and to channelize flow to the inlet structure.

9.2 Outlets

The OPSD 804.030 standard headwall shall be used for all storm sewers up to 900 mm in diameter. For sewers over 900 mm in diameter, the OPSD 804.040 headwall shall be used. All headwalls shall be equipped with a grating over the outlet as per OPSD 804.050.

Suitable erosion protection, which may include gabions, rip rap, concrete or other erosion protection shall be provided to the satisfaction of the regulatory agencies at all outlets to prevent erosion of the watercourse and the area adjacent to the headwall.

9.3 Open Channels

The proposed criteria for an open channel shall be submitted to the Municipal Engineer for their approval. The Consulting Engineer shall be responsible for obtaining the approval from the MNRF, MECP, and the local Conservation Authority, if the open channel concept is favourably considered.

The Conservation Authority shall be consulted during initial project planning in regard to any potential watercourse alterations associated with the development proposal.

Watercourse alterations are subject to permitting requirements under the Authority's Development, Interference with Wetlands and Alterations to Shorelines and Watercourses Regulation (Ontario Regulation 147/06). Planned watercourse alterations may, in addition, be subject to other Agency requirements (Fisheries and Oceans, Canada (DF), MNRF, Navigable Waters (Transport Canada), Drainage Act, etc.).

10.0 MAINTENANCE MANUAL

Prior to completion of the works a maintenance manual shall be provided. This manual shall address the obligations for maintenance, outline the appropriate tasks, and shall provide the frequency of maintenance measures required.

SECTION B – LOT GRADING

1.0 GENERAL

The lot grading of all lots and blocks in new subdivisions must be carefully monitored by the Consulting Engineer in order to provide sites that are suitable for the erection of buildings and to provide satisfactory drainage from all lands within the development.

2.0 LOT GRADING PLANS

All Lot Grading Plans for new development in the Municipality of Kincardine shall be prepared in accordance with the criteria contained in this section and shall contain the following information and detail:

- Scale 1:500 (unless otherwise approved).
- All existing and proposed lot numbers and blocks.
- All proposed rear lot catch basins, leads, top elevations and inverts.
- Location of service connections.
- Existing contours at maximum 0.5 m intervals.
- Existing and proposed elevations at lot corners.
- Specified house grades.
- Proposed road grades, length and elevations on all streets.
- Proposed elevations along the boundary of all blocks abutting single family and semi-detached lots in the subdivision.
- Direction of the surface run-off by means of arrows.
- All proposed easements required for registration.

3.0 LOT GRADING DESIGN

- Generally, the front yards of all lots shall be graded to drain towards the street.
- All boulevards are to be graded with a constant slope from the curb to the street limit. (Minimum slope to be 2.0 percent and the maximum slope to be 6.0 percent).
- All rear yard drainage is to be directed away from the houses in defined swales which outlet at the curb or a catch basin.
- All lot surfaces shall be constructed to a minimum grade of 2.0 percent and a maximum grade of 12.0 percent.
- The maximum slope on all embankments and terraces shall be 3:1 (4:1 preferred).
- The maximum flow allowable to any side yard swale shall be that from two lots plus that from two adjacent lots.

- The maximum number of rear lots contributing to a rear yard swale shall be that of four rear yards.
- The maximum length of a rear yard swale between outlets shall be 90 metres. Where rear yard swales provide drainage for more than one lot, the swale must be located within a 4.0 metre drainage easement over the total length. Rear yard swales shall have a minimum slope of 1.5 percent.
- Swales providing internal drainage from each lot shall have a minimum slope of 2.0 percent.
- Minimum depth of any swale to be 150 mm.
- Maximum depth of rear yard swales to be 500 mm.
- Maximum depth of side yard swales to be 300 mm.
- Maximum side slopes on any swale to be 3:1.
- All drainage swales shall be located on the common lot line between adjacent lots.
- Rear yard catch basins and outlet pipes are to be located entirely on the same lot and shall be located 1.0 metres from the lot line.
- The minimum driveway grade shall be 1.0 percent and the maximum grade permissible shall be 8.0 percent.

4.0 INDIVIDUAL LOT GRADING PLAN

Prior to application for a building permit, individual lot grading plans for each lot shall be prepared and shall be submitted to the Municipal Building Department for approval. These lot grading plans shall include the following:

- Lot description including Registered Plan Number.
- Dimensioned property limits and house location.
- House type; normal, side split, back split, etc.
- Finished floor elevation.
- Finished garage floor elevation.
- Finished and original grades over septic tile beds.
- Finished basement floor elevation.
- Top of foundation wall elevations (all locations).
- Existing and proposed lot elevations.
- Existing trees to be maintained.
- Driveway location, width and proposed grades.
- All sidewalk locations, width and proposed grades.
- Arrows indicating the direction of all surface drainage and swales.
- Location and elevation of swales.
- Location of decks, porches and patios.
- Location of terraces and retaining walls.
- Location and type of any private sewage disposal systems, reserve areas and private wells.
- Location of engineered fill (where required).

- Lot grading certificate by Developer's Engineer in accordance with the subdivision agreement requirements.
- In the case where the lot falls within the Conservation Authority's regulatory limit, the Conservation Authority shall be consulted in regard to any additional information provided on the plan.

4.1 Certification

Prior to the release of any lot from the subdivision agreement, the Developer's Engineer shall provide certification to the Municipality of Kincardine that the grading and drainage of the lot is in general conformity with the approved lot grading and drainage plans.

SCHEDULE 'A'

PRECIPITATION DATA

Environment and Climate Change Canada
 Environnement et Changement climatique Canada

Short Duration Rainfall Intensity-Duration-Frequency Data
 Données sur l'intensité, la durée et la fréquence des chutes
 de pluie de courte durée

Gumbel - Method of moments/Méthode des moments

2022/10/31

=====

GODERICH ON 6122847

Latitude: 43 46'N Longitude: 81 43'W Elevation/Altitude: 213 m

Years/Années : 1970 - 2021 # Years/Années : 36

=====

Table 1 : Annual Maximum (mm)/Maximum annuel (mm)

Year Année	5 min	10 min	15 min	30 min	1 h	2 h	6 h	12 h	24 h
1970	6.6	8.6	12.4	16.0	16.0	16.5	23.1	25.7	36.8
1971	6.6	12.7	14.7	27.4	38.1	42.2	47.2	47.2	47.2
1972	7.4	11.9	15.2	23.9	35.1	63.0	77.5	77.5	77.5
1973	8.4	16.0	20.6	33.8	38.9	44.7	58.4	62.0	62.0
1974	8.9	17.3	18.0	19.0	20.6	22.6	33.5	45.0	47.5
1975	8.1	11.2	16.0	24.1	33.0	36.8	36.8	40.6	41.7
1976	10.7	14.5	20.8	34.8	41.7	41.7	41.7	44.2	57.4
1977	13.2	18.5	22.6	35.1	47.2	71.9	89.9	92.2	93.0
1978	7.0	11.8	14.8	17.1	19.8	23.2	28.8	32.6	45.6
1979	9.5	11.8	11.8	11.8	16.4	20.0	23.4	32.9	33.8
1980	7.0	13.0	15.8	17.1	17.8	18.0	26.2	30.7	32.0
1997	12.6	15.6	18.0	19.8	23.0	26.6	27.0	27.0	33.0
1998	15.0	23.0	30.8	39.2	39.4	39.4	39.4	39.6	39.6
1999	11.2	12.8	13.4	15.4	16.8	18.8	26.6	27.2	33.0
2000	19.8	36.8	44.2	56.0	75.2	79.8	80.2	80.4	80.8
2001	8.6	15.2	17.0	23.0	33.4	40.6	56.2	69.8	71.0
2002	11.8	15.4	21.4	26.2	28.4	28.6	29.6	30.0	35.8
2003	12.8	21.0	28.6	41.0	42.4	42.4	42.4	44.0	44.0
2004	11.8	18.6	22.0	29.8	31.0	31.4	44.2	44.6	44.6
2005	8.0	12.4	16.4	25.6	41.6	47.4	58.0	64.4	64.4
2006	5.2	8.6	11.8	14.8	15.2	15.4	25.8	36.8	37.6

2007	8.2	9.8	11.4	13.8	21.6	24.4	26.2	30.2	30.2
2008	11.0	13.2	15.0	24.8	26.6	36.2	51.0	56.2	105.8
2009	6.8	12.2	14.4	21.0	23.6	31.0	31.0	33.4	41.8
2010	9.4	16.0	21.0	26.2	38.6	41.4	51.2	51.2	51.4
2011	8.8	15.6	20.4	31.6	37.2	37.2	37.2	37.4	40.0
2012	6.4	9.2	11.6	15.0	16.6	19.6	24.6	36.6	37.4
2013	7.2	11.6	15.2	18.8	19.6	27.0	33.6	35.8	36.6
2014	6.4	10.4	13.0	17.8	20.8	21.6	27.4	29.6	33.2
2015	5.6	7.2	9.2	11.8	19.8	28.4	38.4	38.4	38.6
2016	6.6	9.8	13.6	24.6	41.2	59.4	61.0	68.0	72.8
2017	13.6	24.4	29.4	36.4	43.4	47.0	72.2	74.4	88.0
2018	11.0	12.6	15.4	19.4	24.4	32.2	49.8	60.8	61.2
2019	8.0	12.2	12.4	15.8	17.6	30.0	31.0	38.0	38.0
2020	11.6	17.2	21.2	21.8	23.8	30.0	36.2	42.2	50.0
2021	8.6	14.0	15.8	29.8	32.6	32.8	33.0	45.6	64.0

# Yrs. Années	36	36	36	36	36	36	36	36	36
Mean Moyenne	9.4	14.5	17.9	24.4	30.0	35.3	42.2	46.5	51.3
Std. Dev. Écart-type	3.1	5.5	6.8	9.5	12.5	15.1	17.4	17.2	19.4
Skew. Dissymétrie	1.26	2.17	1.98	1.19	1.34	1.20	1.15	1.01	1.19
Kurtosis	5.35	10.03	8.39	5.10	6.35	4.64	3.86	3.37	3.83

*-99.9 Indicates Missing Data/Données manquantes

Warning: annual maximum amount greater than 100-yr return period amount
Avertissement : la quantité maximale annuelle excède la quantité pour une période de retour de 100 ans

Year/Année	Duration/Durée	Data/Données	100-yr/ans
2000	5 min	19.8	19.1
2000	10 min	36.8	31.7
2000	15 min	44.2	39.3
2000	30 min	56.0	54.4
2000	1 h	75.2	69.2

Table 2a : Return Period Rainfall Amounts (mm)
Quantité de pluie (mm) par période de retour

Duration/Durée	2 yr/ans	5 yr/ans	10 yr/ans	25 yr/ans	50 yr/ans	100 yr/ans	#Years Années
5 min	8.9	11.6	13.4	15.7	17.4	19.1	36
10 min	13.6	18.4	21.6	25.7	28.7	31.7	36
15 min	16.8	22.8	26.8	31.9	35.6	39.3	36

30 min	22.9	31.3	36.9	43.9	49.2	54.4	36
1 h	27.9	39.0	46.3	55.5	62.4	69.2	36
2 h	32.8	46.2	55.0	66.2	74.5	82.8	36
6 h	39.4	54.7	64.9	77.8	87.3	96.8	36
12 h	43.6	58.8	68.8	81.5	91.0	100.3	36
24 h	48.1	65.3	76.6	91.0	101.6	112.1	36

Table 2b :

Return Period Rainfall Rates (mm/h) - 95% Confidence limits
 Intensité de la pluie (mm/h) par période de retour - Limites de confiance de 95%

Duration/Durée	2	5	10	25	50	100	#Years
	yr/ans	yr/ans	yr/ans	yr/ans	yr/ans	yr/ans	Années
5 min	107.1	139.7	161.2	188.5	208.7	228.8	36
	+/- 11.1	+/- 18.6	+/- 25.1	+/- 33.9	+/- 40.6	+/- 47.3	36
10 min	81.6	110.6	129.8	154.1	172.1	190.0	36
	+/- 9.8	+/- 16.6	+/- 22.4	+/- 30.2	+/- 36.1	+/- 42.1	36
15 min	67.2	91.3	107.3	127.5	142.5	157.3	36
	+/- 8.2	+/- 13.8	+/- 18.6	+/- 25.1	+/- 30.0	+/- 35.0	36
30 min	45.7	62.6	73.8	87.9	98.3	108.7	36
	+/- 5.7	+/- 9.6	+/- 13.0	+/- 17.6	+/- 21.0	+/- 24.5	36
1 h	27.9	39.0	46.3	55.5	62.4	69.2	36
	+/- 3.7	+/- 6.3	+/- 8.5	+/- 11.5	+/- 13.8	+/- 16.0	36
2 h	16.4	23.1	27.5	33.1	37.3	41.4	36
	+/- 2.3	+/- 3.8	+/- 5.2	+/- 7.0	+/- 8.3	+/- 9.7	36
6 h	6.6	9.1	10.8	13.0	14.6	16.1	36
	+/- 0.9	+/- 1.5	+/- 2.0	+/- 2.7	+/- 3.2	+/- 3.7	36
12 h	3.6	4.9	5.7	6.8	7.6	8.4	36
	+/- 0.4	+/- 0.7	+/- 1.0	+/- 1.3	+/- 1.6	+/- 1.8	36
24 h	2.0	2.7	3.2	3.8	4.2	4.7	36
	+/- 0.2	+/- 0.4	+/- 0.6	+/- 0.7	+/- 0.9	+/- 1.0	36

Table 3 : Interpolation Equation / Équation d'interpolation: $R = A \cdot T^B$

R = Interpolated Rainfall rate (mm/h)/Intensité interpolée de la pluie (mm/h)

RR = Rainfall rate (mm/h) / Intensité de la pluie (mm/h)

T = Rainfall duration (h) / Durée de la pluie (h)

Statistics/Statistiques	2	5	10	25	50	100
	yr/ans	yr/ans	yr/ans	yr/ans	yr/ans	yr/ans
Mean of RR/Moyenne de RR	39.8	53.7	62.9	74.5	83.1	91.6

Std. Dev. /Écart-type (RR)	38.1	50.3	58.4	68.7	76.3	83.9
Std. Error/Erreur-type	13.3	19.8	24.1	29.5	33.5	37.5
Coefficient (A)	23.4	32.0	37.6	44.7	50.0	55.3
Exponent/Exposant (B)	-0.721	-0.717	-0.715	-0.714	-0.713	-0.712
Mean % Error/% erreur moyenne	12.6	14.3	15.0	15.7	16.0	16.3

SCHEDULE 'B'

FOUNDATION DRAIN DETAIL

Foundation Drain Discharge Collection System for Single-Detached, Semi-Detached or Duplex House

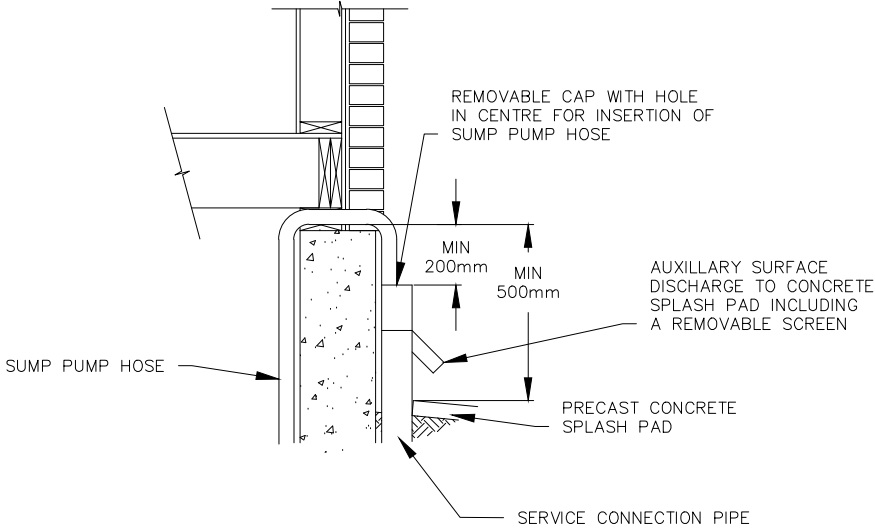

TYPICAL DETAIL "A"

NOTE:
ROOF LEADERS (DOWNSPOUTS) OR ANY OTHER STORM WATER SOURCE MUST NOT BE CONNECTED TO THE FOUNDATION DRAIN DISCHARGE COLLECTION SYSTEM.

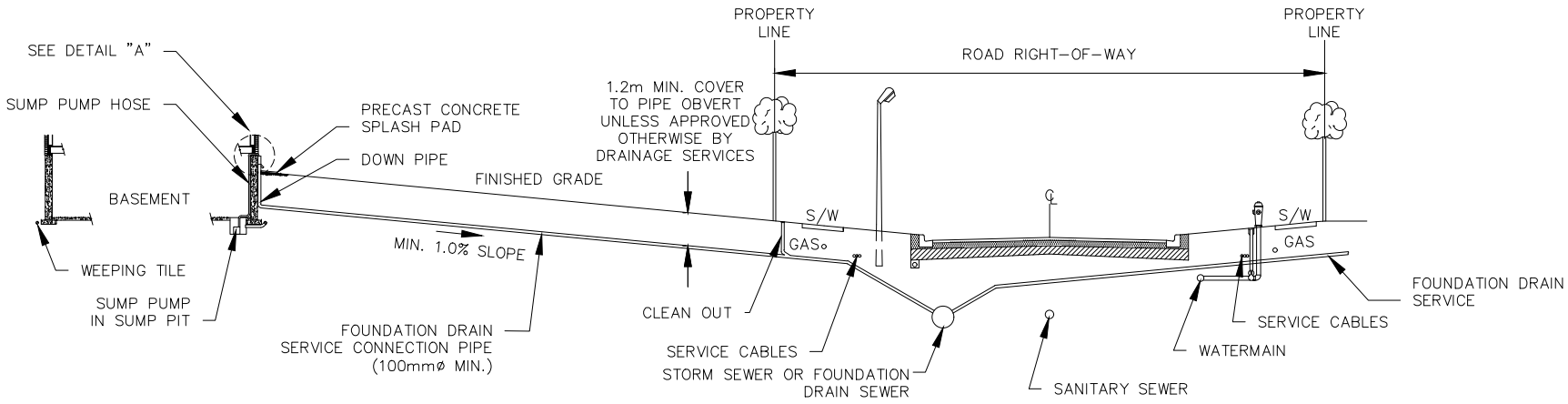

SCALE: N.T.S.



**Municipality of
Kincardine**

**Foundation Drain Detail
for Private Drain Connections**

DATE OF REVISION - Feb. 22, 2023



APPENDIX “D”

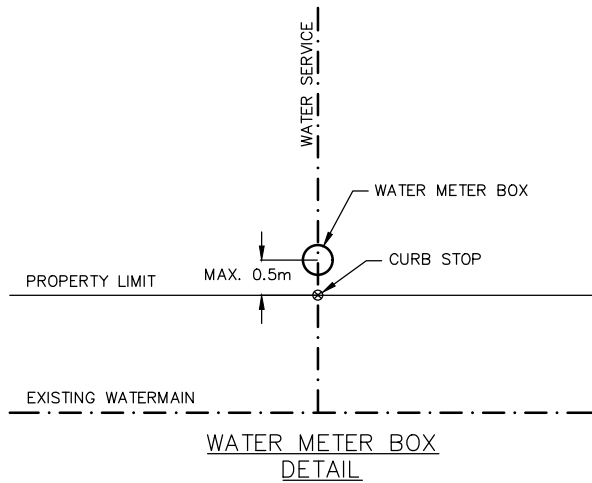

**METER BOX CONNECTION FOR
MULTIPLE RESIDENTIAL UNITS FOR TYPICAL SINGLE LOT**

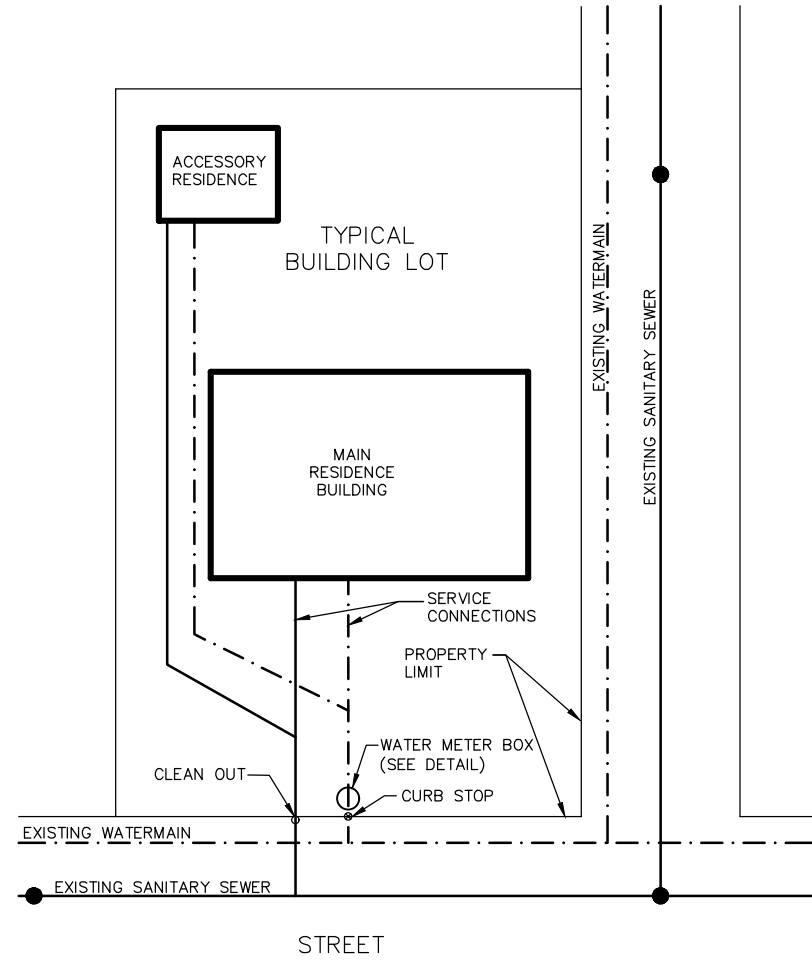

NOTES:

1. MINIMUM SANITARY SERVICE SIZE 150mm FOR THREE RESIDENTIAL UNITS OR MORE, UNLESS DESIGN CALCULATIONS JUSTIFY A SMALLER SIZE TO THE SATISFACTION OF THE MUNICIPALITY OF KINCARDINE.
2. MINIMUM WATER SERVICE SIZE 25mm FOR THREE RESIDENTIAL UNITS OR MORE.
3. WATER METER BOX REQUIRED JUST INSIDE THE PROPERTY LIMIT FOR ALL MULTI-UNIT RESIDENCES WITHIN A FORMER SINGLE FAMILY DWELLING.
4. WATER METER BOX SHALL BE A MUELLER THERMAL-COIL METER BOX:
MODEL # 203 CS 15 66 A F A S N
INSTALLED AS RECOMMENDED BY THE MANUFACTURER
5. WATER METER SHALL BE MAINTAINED AS PER THE KINCARDINE WATER USE BY-LAW, METER BOX SHALL BE MAINTAINED BY THE PROPERTY OWNER.
6. WATER AND SANITARY SERVICES INSTALLED IN PARALLEL, SHALL HAVE A MINIMUM SEPARATION 2.5m HORIZONTAL FROM PIPE EDGE TO PIPE EDGE. WITH A MINIMUM VERTICAL SEPARATION OF 0.5m.
7. BACKFILL MATERIAL SHALL BE CLEAR OF STONES, BOULDERS AND FROZEN MATERIAL AND TAMPED IN 300mm LIFTS OVER THE PIPE.
8. PIPE BEDDING SHALL BE AS PER OPSD 802.010, 802.013 OR 802.014 FOR FLEXIBLE PIPE FOR WHICHEVER SOIL IS APPLICABLE. COMPACTION SHALL BE IN ACCORDANCE WITH OPSS 501
9. NO WATER SERVICE COUPLERS ARE PERMITTED BETWEEN THE MAIN STOP AND CURB STOP, CURB STOP AND METER, METER AND MANUFACTURED BENDS, TEES OR WYES, MANUFACTURED BENDS, TEES OR WYES AND THE CONNECTION TO THE SECONDARY RESIDENT UNIT(S).
10. ENSURE THAT CONNECTION AT CURB STOP CONSISTS OF BRASS COMPRESSION FITTING WITH STEEL INSERT.
11. CONNECTION(S) SHALL BE VERIFIED BY THE WATER PURVEYOR OR DESIGNATE
12. WATER SERVICES SHALL BE A MINIMUM OF 1.5m (5ft) DEEP (BELOW FROST LEVEL). PIPING SHALL BE CSA B137 SERIES 160 OR BETTER. SERVICE SHALL INCLUDE TRACER WIRE.
13. WATER SERVICE SHALL BE A SINGLE RUN WITH NO JOINTS WITHIN 2.4m OF ANY SANITARY SERVICE.
14. WATER SERVICE SHALL BE PRESSURE TESTED TO 100PSI FOR 2 HOURS (TYPICALLY IF JOINTS ARE PRESENT)
15. CONNECTION INSIDE THE BUILDING SHALL BE THROUGH A BUILDING CONTROL VALVE AND METER ASSEMBLY AS PER THE WATER PURVEYOR'S REQUIREMENTS.



 <p style="font-size: small;">THE MUNICIPALITY OF KINCARDINE great energy. balanced life.</p>	<p>Municipality of Kincardine</p>	<p>DATE OF REVISION - JUN 21, 2024</p>
	<p>Meter Box Connection for Multiple Residential Units For Typical Single Lot</p>	 <p style="font-size: x-small;">BMROSS engineering better communities</p>